

PH

adira

METAL FORMING SOLUTIONS



PRESS BRAKES PH

TECHNICAL DATA SHEETS

Press Brakes

PH

The range of PH press brakes is ADIRA's answer to the most demanding needs of our customers — "heavy-duty".



Ram parallelism
(hydraulic synchronisation).



Bending depth.

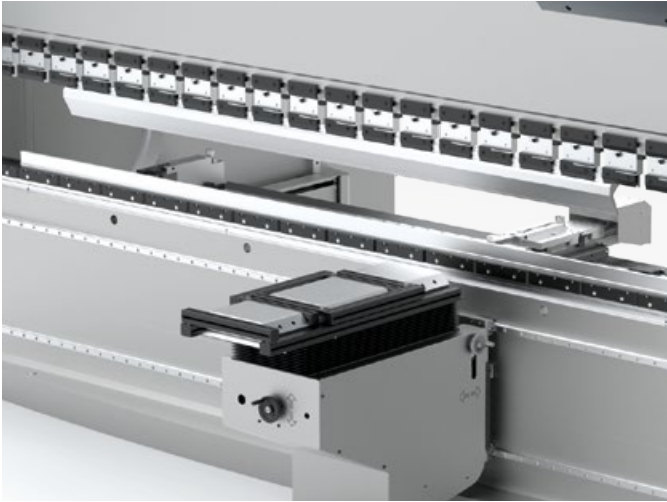

Main Features

Four-point guiding system, with few maintenance requirements

Assurance of adequate alignment between tools Ram slope for conical bending

Dedicated CNC controls (controlling parallelism and bending depth)

Optoelectronic protection system in the form of non-material barriers or a laser beam

Very high approximation speed

Deep arch

Wide opening and long stroke

Benefits

Easy regulation of the bending depth (with the ram in loading condition for sheet metal);

Electric-hydraulic synchronisation of the movable ram (Y_1 and Y_2 axes);

Electric-hydraulic stoppage of the movable ram at 0.01 mm;

Comprehensive programming of the bending angle;

Movable ram slope programming (Y_1 e Y_2);

Programming work/return speeds (10-100%).

With a bending capacity of up to 20,000 kN and lengths of up to 8 metres (tandem solutions can handle longer lengths), this range has electric-hydraulic controls.

The position of the ram is constantly monitored through linear guides located at the ends of the frame, ensuring **0.01 mm of repeatability of ram positioning.**



TECHNICAL DATA SHEETS

Press Brake PH

PH		16046	22060	30040	30060	30070	40040	40060	40070	50040	50060	50070	60040
Bending strength	kN	1600	2200	3000	3000	3000	4000	4000	4000	5000	5000	5000	6000
Max. bending length	mm	6050	6050	4050	6050	7050	4050	6050	7050	4050	6050	7050	4050
Distance between side frames	mm	3150	5100	3150	5100	6150	3150	5100	6150	3150	5100	6150	3150
Maximum stroke	mm	250	250	250	250	250	250	250	250	250	250	250	300
Max. opening without	mm	500	500	530	530	530	530	530	530	530	530	530	600
Special stroke, no. 1	mm	-	400	400	400	400	400	400	400	400	400	400	400
Max. special stroke, no. 1	mm	-	-	-	630	630	630	630	630	630	630	630	630
Special stroke, no. 2	mm	-	-	-	500	500	500	500	500	500	500	500	500
Max. special stroke, no. 2	mm	-	-	-	800	800	800	800	800	800	800	800	800
Throat Depth	mm	630	400	400	400	400	400	400	400	400	400	400	400
Special Throat Depth, no. 1	mm	-	630	630	630	630	630	630	630	630	630	630	630
Special Throat Depth, no. 2	mm	-	-	800	800	800	800	800	800	800	800	800	800
Special Throat Depth, no. 3	mm	v	-	1000	1000	1000	1000	1000	1000	1000	1000	1000	1000
Power	kW	15	15	18	18	18	30	30	30	30	30	30	30
Approach Speed	mm/s	150	130	150	150	150	150	150	150	80	80	80	80
Working speed	mm/s	10	8	8	8	8	9	9	9	8.5	8.5	8.5	7.5
Return speed	mm/s	100	85	100	100	100	90	90	90	75	75	75	75
Length*	mm	7160	7000	4820	7000	7650	4400	7000	8100	4400	7000	8100	4400
Width*	mm		2180	2380	2380	2380	2380	2380	2380	2380	2380	2380	2600
Height*	mm	3170	3540	3450	3500	3950	3450	3700	4050	3650	4280	4600	4200
Height of workstation	mm	950	1050	950	1100	860	1000	860	860	1080	860	860	1100
Distance below the ground	mm	-	-	-	-	1500	-	1400	1900	-	1500	1900	-
Approx. mass	Kg	16500	24000	19000	35000	40000	25000	38000	44000	32000	45000	59000	42000



* merely indicative values.

	60060	60070	80060	80070	110060	110070	110080	135060	135070	135080	135090	160075	200070	200080
	6000	6000	8000	8000	11000	11000	11000	13500	13500	13500	13500	16000	20000	20000
	6050	7050	6050	7050	6050	7050	8050	6050	7050	8050	9050	7500	7000	8000
	5100	6150	5100	6150	5100	6150	6800	5100	6150	6800	8100	6200	5500	6500
	300	300	300	300	300	300	300	300	300	300	300	640	300	300
	600	600	600	600	700	700	700	700	700	700	700	1000	700	700
	400	400	400	400	400	400	400	400	400	400	400	-	-	-
	630	630	630	630	800	800	800	800	800	800	800	-	-	-
	500	500	500	500	500	500	500	500	500	500	500	-	-	-
	800	800	800	800	900	900	900	900	900	900	900	-	-	-
	400	400	400	400	400	400	400	400	400	400	400	640	500	500
	630	630	630	630	630	630	630	630	630	630	630	-	-	-
	800	800	800	800	800	800	800	800	800	800	800	800	-	-
	1000	1000	1000	1000	1000	1000	1000	1000	1000	1000	1000	1000	-	-
	30	30	2x22	2x22	2x30	2x30	2x30	2x30	2x30	2x30	2x30	2x30	2x55	2x55
	80	80	80	80	80	80	80	80	80	80	80	80	70	80
	7.5	7.5	7.5	7.5	7	7	7	6.5	6.5	6.5	6.5	6.5	8.5	9
	75	75	75	75	80	80	80	83	83	83	83	90	95	95
	7000	8100	7000	8100	7000	8100	9200	7000	8100	9200	10200	8700	8200	9200
	2600	2600	2700	2700	2900	2900	2900	3200	3200	3200	3200	3250	3500	3500
	4450	4700	4600	4900	4700	5050	5430	5300	5600	5700	5900	5700	5120	5230
	860	860	860	860	860	860	860	860	860	860	860	850	900	900
	1500	2000	1750	2100	2000	2250	2400	2600	2850	2950	3025	2850	2800	2980
	50000	6400	70000	79000	92000	112000	125500	100000	115000	127500	140000	150000	148000	155000

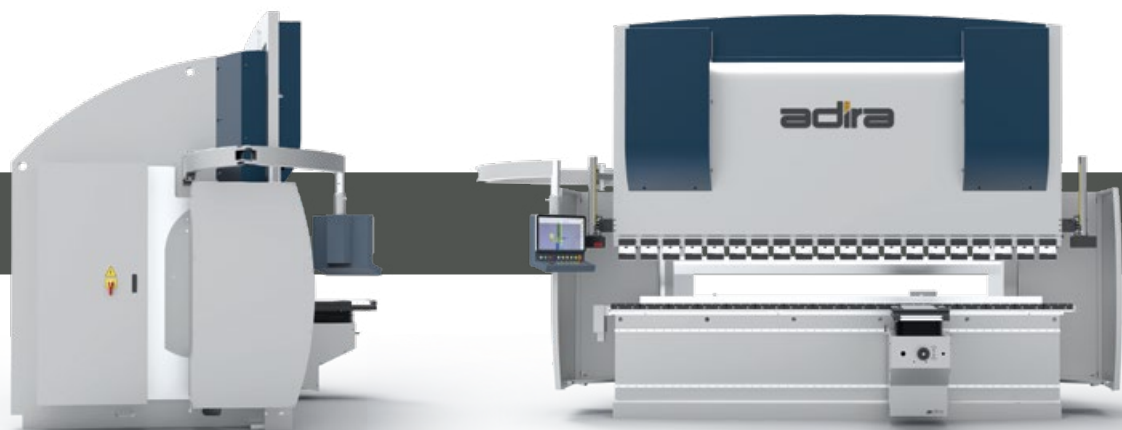

TECHNICAL DATA SHEETS



Equipment	PH	
Punch Tightening	"ADIRA" punch holders and non-reversible	standard
	Wila Premium Hydraulic Punch Clamping	■
	Wila Premium Hydraulic Punch Tightening	■
	Wila Premium USA Hydraulic Punch Clamping	■
Tables	Crowning Table, base 60, "Standard Table Kit"	standard
	Wila Premium Hydraulic Clamping with Crowning table	■
Sheet metal support arms	Fixed, light-duty front arms (L = 500 mm) (pack of 3 for machines = 4 m, pack of 4 for machines > 4 m)	standard
	1 additional support arm on rail (without height adjustment, without brushes, L = 500 mm)	■
	2 support arms on heavy-duty rail (L = 1000 mm)	■
	1 additional support arm on rail (with height adjustment, with brushes, L = 1000 mm)	■
	Light-duty bending aids (AQ1 + AQ2) (capacity 75 kg)	■
Back gauges	2 stops (only on machines with X/R)	standard
	X/R/Z1/Z2 back gauge for AD25	■
	X/R/Z1/Z2 back gauge for CYBTOUCH 15	■
	X/R/Z1/Z2 back gauge for AD61	■
	X/R/Z1/Z2 back gauge for Delem 6X	■
	X/X1/R/Z1/Z2 back gauge for AD61	■
	X/X1/R/Z1/Z2 back gauge for Delem 6X	■
	1 extra light-duty back gauge stop	■
Angle Measurement Safety	LZS- LG Laser Safety (PHs - only 4 m)	standard
	No safety	■
	IRIS Laser Safety (PHs - larger than 4 m)	standard
Controls	Adcontrol 40	standard
	DELEM DA 69_3D (up to 16 axes)	■
	CYB VISIPAC	■
	Adcontrol 75	■
Other	UPS	■
	Interface with Robot	■
	Adaptation to High Temperatures	■
	Adaptation to Low Temperatures	■
	Air Conditioning on the Electrical Cabinet	■
	Special Tools	on request
	Digital Goniometer	■
	2 Machines in tandem	on request



Rua das Lages 67 . 4410-272 Vila Nova de Gaia

T.: +351 226 192 700 . adira@adira.pt