

The logo for ERLO, featuring the letters 'ERLO' in a bold, sans-serif font. The 'E' is black, while the 'R' is blue with a white diagonal line through it. The 'L' and 'O' are black. The background of the entire page is a grayscale 3D rendering of various industrial drill bits and tool components, some with a metallic finish and others with a matte black finish, arranged in a dynamic, overlapping composition.

**ERLO**

*Drills / Units / CNC*

**CATALOGUE  
2023**





Drills / Units / CNC

**PROFESSIONAL**

**PREMIUM**

# INDEX

## PROFESSIONAL LINE

SERIE V-VP 40	PAGE 28-29
SERIE V-VP 35	PAGE 30-31
SERIE G-GP-32	PAGE 32-33
SERIE GP-40-50	PAGE 34-35

## BENCH TYPE PREMIUM DRILLING MACHINES

SERIE S	PAGE 4-5
SERIE SE - SEA	PAGE 6-7
CUSTOMIZE YOUR TAPPING MACHINE	PAGE 8-9
SERIE SH	PAGE 10-11
SERIE SHE-SHEA	PAGE 12-13
SERIE FT	PAGE 14-15

## COLUMN PREMIUM DRILLING MACHINES

SERIE C	PAGE 16-17
SERIE TS-TSA.25-30	PAGE 18-19
SERIE TSA-TSE.32-35	PAGE 20-21
SERIE TSA-TSE.40-45	PAGE 22-23
SERIE TCA-TCE	PAGE 24-25
SERIE TH	PAGE 26-27

## PRISMATIC COLUMN PREMIUM DRILLING MILLING MACHINE

SERIE TF	PAGE 36-37
----------	------------

## GANG DRILLING MACHINES

PAGE 38-39
------------

## SELECTION AND FEATURES OF A DRILLING/TAPPING MACHINE

PAGE 40
---------

## EXTRA ACCESSORIES

PAGE 41-45
------------

# SERIE S

## BENCH TYPE DRILLING MACHINES

- Manual feed
- V-belt drive
- Fixed table, displaceable and rotating headstock

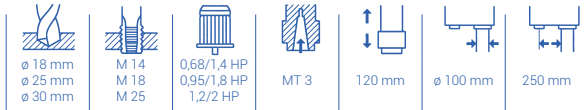

## Standard equipment

- Table/base with "T" slots
- Adjustable depth end
- Lighting equipment
- Tool ejector
- Belt cover with stop micro
- Motor guard and emergency push button
- Emergency push button
- Main switch
- Turning sense selector
- Electrical equipment at low voltage
- Electrical equipment in a separate cabinet
- Drill guard with stop micro
- CE norms



S.18

## Extra Equipment

	CODE
V - FRONTAL WHEEL FOR FINE SENSITIVE FEED	10020
TAK - SPEED DIGITAL READER (FOR MODELS WITH ELECTRONIC VARIATOR)	10021
LBC - DEPTH DIGITAL READER	10022
VE - EXTRA PRICE FOR ELECTRONIC VARIATOR	10023
IR/RS - MANUAL TAPPING SYSTEM IR/RS	10042
IR/RS (VE) - MANUAL TAPPING SYSTEM IR/RS (FOR MODELS WITH VARIATOR)	10043
PKB - BASE CABINET WITH DOOR AND SHELVES	10082
PKA - BASE CABINET WITH 2 SHELVES (ONLY FOR BENCH DRILLING MODELS WITHOUT COOLANT)	10083
PKC - BASE CABINET (ONLY FOR MODELS WITH INTERMEDIATE TABLE)	10084
CC - CYCLES COUNTER (FOR MACHINES WITH HIDROBLOCK)	10085
MIF - FIXED INTERMEDIATE TABLE	10087
MIG - ROTATING INTERMEDIATE TABLE	10088
SC - COLUMN SUPPLEMENT 200 MM.	10110
HB - EXTRA PRICE FOR HYDROBLOCK EQUIPMENT	10120
ERB - COOLANT EQUIPMENT	91118

\*\* In machines with intermediate table, the base cabinet has not the drawer. (ref. PKC)

# Characteristics

	<b>S.18</b>	<b>S.25</b>	<b>S.30</b>
DRILLING CAPACITY IN STEEL OF 70 Kg. (mm)	18	25	30
TAPPING CAPACITY IN STEEL OF 70 Kg.	M14	M18	M25
TRANSMISSION	V-BELT		
SPEED NUMBER AND RANGE (WITHOUT VARIATOR) 50 HZ.	(10) 245 - 355 - 490 - 710 - 835 - 1.240 - 1.670 - 2.000 - 2.480 - 4.000 rpm.		
SPEED NUMBER AND RANGE (WITH VARIATOR)	VARIABLES A) 120-760 B) 170-1100 C) 400-2580 D) 600-3800 E) 950-6000 rpm.		
FEED	MANUAL		
MAIN MOTOR POWER (WITHOUT VARIATOR) MOTOR 1500 rpm.	0,68/1,4 HP	0,95/1,8 HP	1,2/2 HP
MAIN MOTOR POWER (WITH VARIATOR) MOTOR 1000 rpm.	1,5 HP	2 HP	2 HP
SPINDLE CONE	MT.3		
SPINDLE STROKE	120 mm		
SPINDLE STROKE WITH HYDROBLOCK	90 mm		
DISTANCE SPINDLE-COLUMN	250 mm		
DISTANCE SPINDLE-TABLE (MODELS WITHOUT COOLANT)	Min. 155 mm/ Max. 485 mm		
DISTANCE SPINDLE-TABLE (MODELS WITH COOLANT)	Min. 225 mm/ Max. 555 mm		
COLUMN DIAMETER	Ø100 mm		
DIMENSIONS OF THE TABLE/BASE (WITHOUT COOLANT)	270x270 mm		
DIMENSIONS OF THE TABLE/BASE (WITH COOLANT)	316x288 mm		
WEIGHT: NET / GROSS Kg.	190 / 200 Kg.		
PACKAGING DIMENSIONS AND VOLUME	0,87x0,57x1,4 / 0,65 m <sup>3</sup>		
WEIGHT: NET / GROSS KG. WITH BASE CABINET	240 / 260 Kg.		
PACKAGING DIMENSIONS AND VOLUME WITH BASE CABINET	2,25x0,6x0,8 / 1,08 m <sup>3</sup>		

# Dimensions

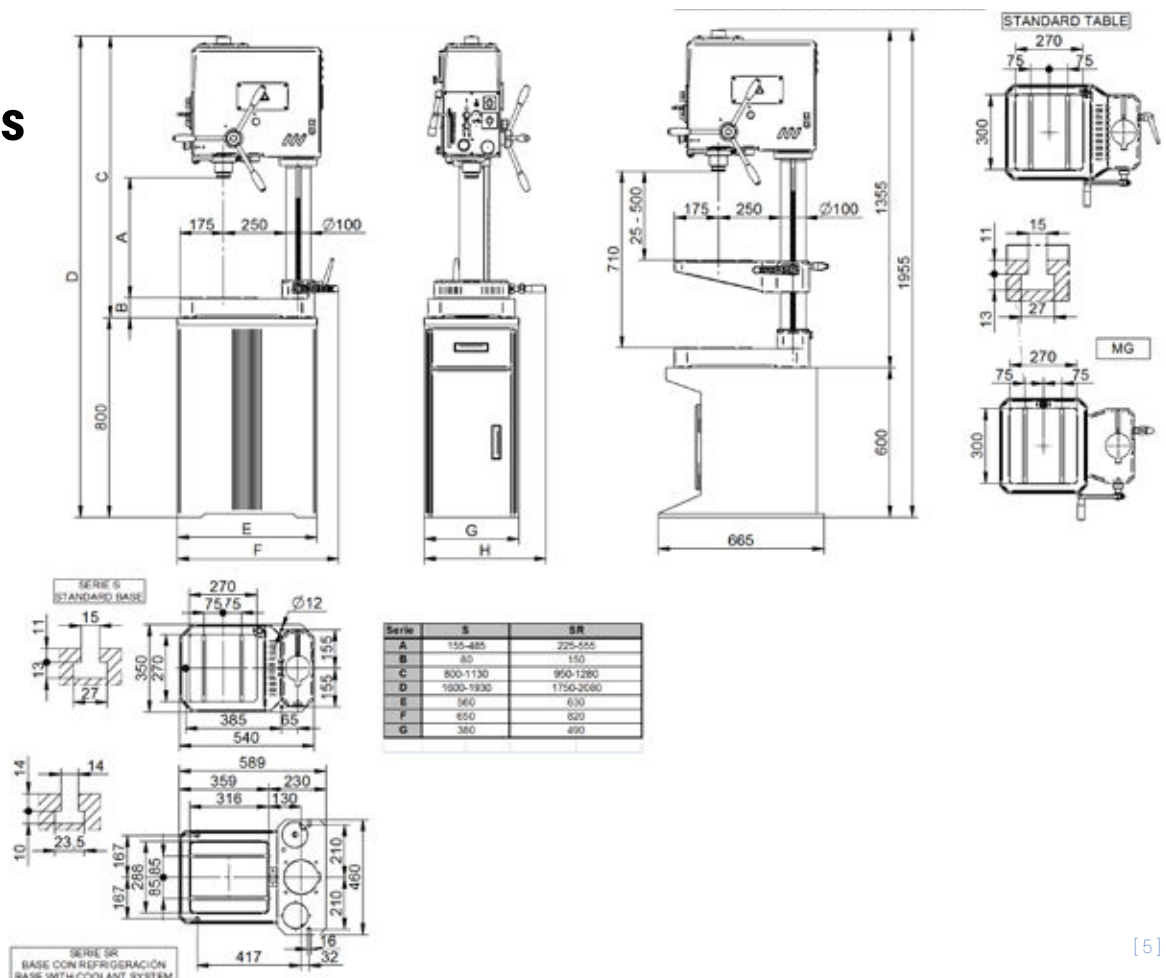

# SERIE SE-SEA

## BENCH TYPE DRILLING MACHINES

- Manual feed (serie SE) and automatic feed (serie SEA)
- Geared drive
- Fixed table, displaceable and rotating headstock



## Standard equipment

- Table/base with "T" slots
- Adjustable depth end
- Lighting equipment
- Tool ejector
- Motor guard and emergency push button
- Turning sense selector
- Main switch
- Electrical equipment at low voltage
- Electrical equipment in a separate cabinet
- Drill guard with stop micro
- CE norms



SE.25

## Extra Equipment

	CODE
V - FRONTAL WHEEL FOR FINE SENSITIVE FEED (ONLY FOR SE SERIE)	10020
TAK - SPEED DIGITAL READER (FOR MODELS WITH ELECTRONIC VARIATOR)	10021
LBC - DEPTH DIGITAL READER	10022
VE - EXTRA PRICE FOR ELECTRONIC VARIATOR	10023
IR/RS - MANUAL TAPPING SYSTEM IR/RS	10042
IR/RS (VE) - MANUAL TAPPING SYSTEM IR/RS (FOR MODELS WITH VARIATOR)	10043
PKB - BASE CABINET WITH DOOR AND SHELVES	10082
PKA - BASE CABINET WITH 2 SHELVES (ONLY FOR BENCH DRILLING MODELS WITHOUT COOLANT)	10083
PKC - BASE CABINET (ONLY FOR MODELS WITH INTERMEDIATE TABLE)	10084
CC - CYCLES COUNTER (FOR MACHINES WITH HIDROBLOCK)	10085
MIF - FIXED INTERMEDIATE TABLE	10087
MIG - ROTATING INTERMEDIATE TABLE	10088
SC - COLUMN SUPPLEMENT 200 MM.	10110
HB - EXTRA PRICE FOR HYDROBLOCK EQUIPMENT (ONLY FOR SE MODELS)	10120
EXTRA PRICE FOR 750/1500 RPM. MOTOR	81000
ERB - COOLANT EQUIPMENT	91118

\* In machines with intermediate table, the base cabinet has not the drawer (ref. PKC)

# Characteristics

	SE.25	SE.30	SEA.25	SEA.30
DRILLING CAPACITY IN STEEL OF 70 Kg. (mm)	25	30	25	30
TAPPING CAPACITY IN STEEL OF 70 Kg.	M22	M25	M22	M25
TRANSMISSION	GEARS (Hardened and ground)			
SPEED NUMBER AND RANGE (WITHOUT VARIATOR)	(8) 65 - 125 - 185 - 365 - 540 - 1.055 - 1.560 - 3.060 rpm.			
SPEED NUMBER AND RANGE (WITH VARIATOR)	VARIABLE A) 45-125 B) 125-370 C) 380-1070 D) 1100-3100 rpm			
FEED	MANUAL	MANUAL	AUTOMATIC	AUTOMATIC
NUMBER AND RANGE OF FEEDS	-	-	(2) 0,10-0,20	(2) 0,10-0,20
MAIN MOTOR POWER (WITHOUT VARIATOR) MOTOR 1500/3000 rpm.	1,1/1,6 HP	1,5/1,9 HP	1,1/1,6 HP	1,5/1,9 HP
MAIN MOTOR POWER (WITH VARIATOR) MOTOR 1500 rpm.				2 HP
SPINDLE CONE				MT.3
SPINDLE STROKE				120 mm
SPINDLE STROKE WITH HYDROBLOCK (SERIE SE)	90 mm	90 mm	-	-
DISTANCE SPINDLE-COLUMN				250 mm
DISTANCE SPINDLE-TABLE (MODELS WITHOUT COOLANT)				Min. 155 / Max. 485 mm
DISTANCE SPINDLE-TABLE (MODELS WITH COOLANT)				Min. 225 / max. 555 mm
COLUMN DIAMETER				Ø100 mm
DIMENSIONS OF THE TABLE/BASE (WITHOUT COOLANT)				270x270 mm
DIMENSIONS OF THE TABLE/BASE (WITH COOLANT)				316x288 mm
WEIGHT: NET / GROSS Kg.				200 / 210 Kg.
PACKAGING DIMENSIONS AND VOLUME				0,8x0,6x1,45 / 0,7 m <sup>3</sup>
WEIGHT: NET / GROSS KG. WITH BASE CABINET				240 / 260 Kg.
PACKAGING DIMENSIONS AND VOLUME WITH BASE CABINET				2,25x0,6x0,8 / 1,08 m <sup>3</sup>

# Dimensions

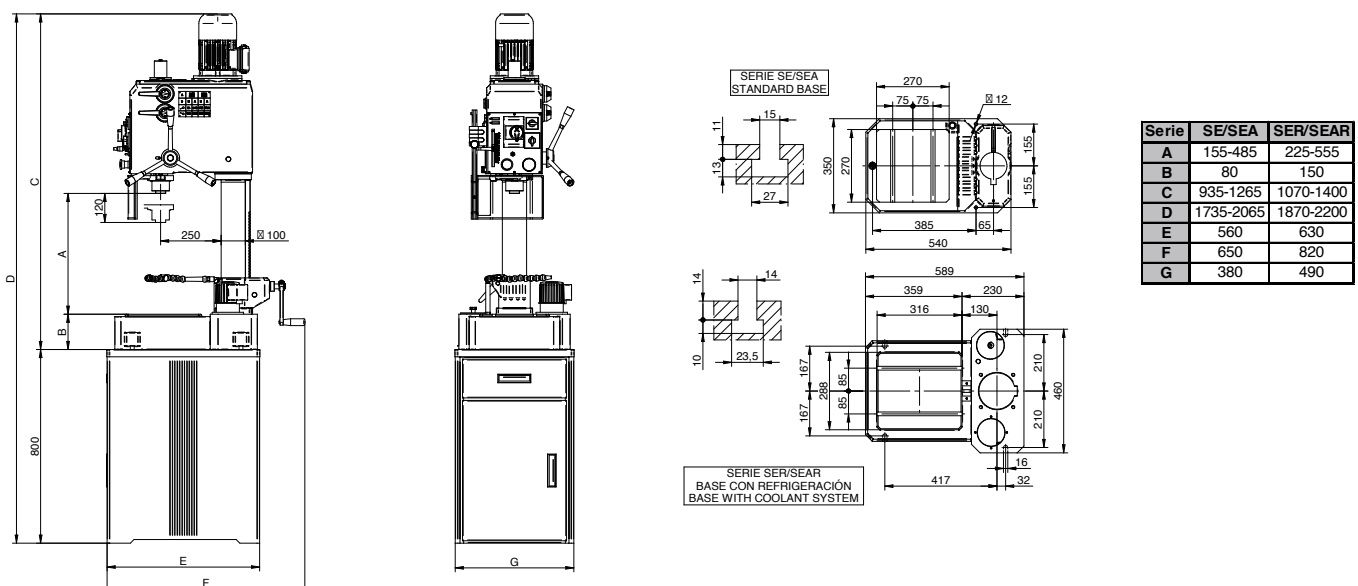

# TAPPING MACHINES

## BENCH AND COLUMN TAPPING MACHINES

**All the drills of ERLO can be turned into automatic threaders if equipped with the optional equipment RHP - Threaded by standard spindle with variator braking device (includes a thread step).**

Moreover, any drill becomes a sensitive feed manual tapping machine when equipped with the optional IR/RS - Automatic rotation reversal for manual threading.

**All drills equipped with either of these two tapping systems maintain drilling functionality.** To do this, simply remove the RHP or deselect the threading function in the IR/RS.

\* The RHP system includes the IR/RS.

### *Tapping systems explanation*

**RHP**

The RHP consists of a system that, by means of a standard spindle and a nut, copies / emulates the thread step in the workpiece to be machined.



*RHP system*

**IR/RS**

The IR/RS consists of a system that automatically reverses the direction of rotation of the tool once it reaches the bottom of the thread. Note that this threading system has a manual feed only.

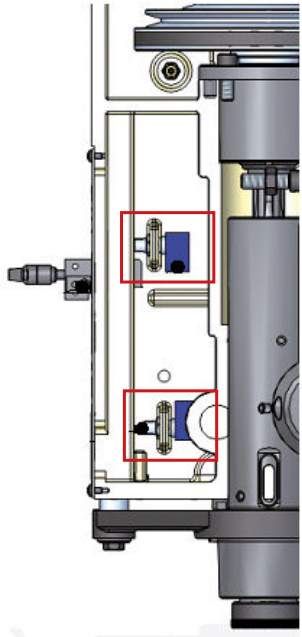



# CUSTOMIZE YOUR TAPPING MACHINE

The **ERLO** bench and column drills with the optional equipment RHP or IR/RS equipment in the series can be converted into a threader. Examples of possible screw configurations.

## Example of a bench tapping machine

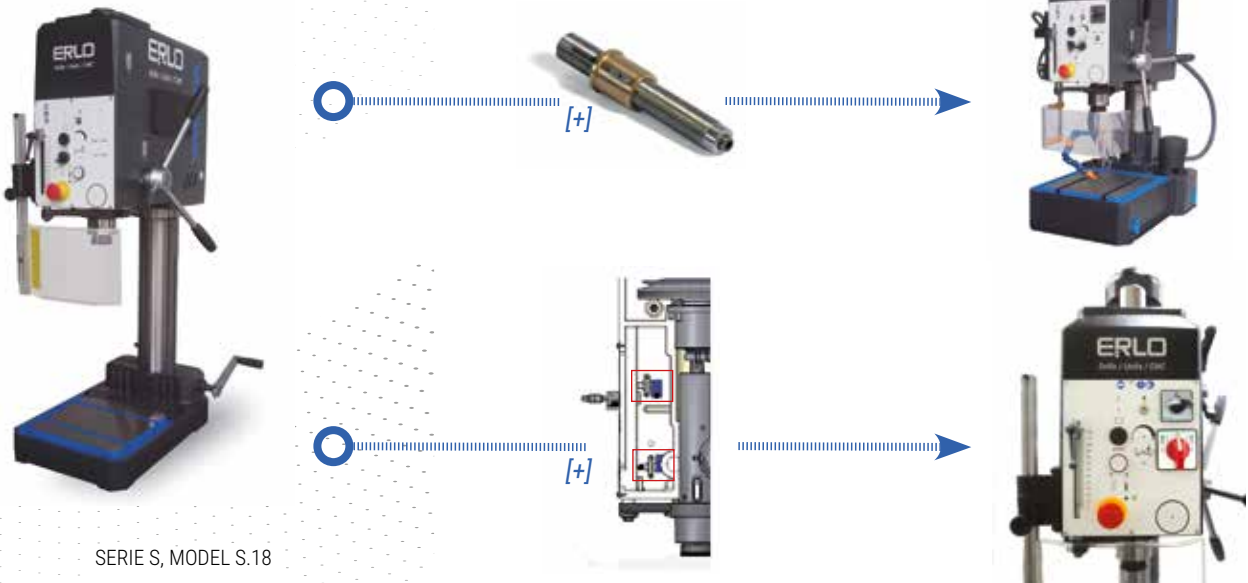

SERIE S, MODEL S.18

### CHARACTERISTICS

- Feed pattern spindle threading automatic
- Manual drilling feed
- Transmission belts



## Example of a column tapping machine

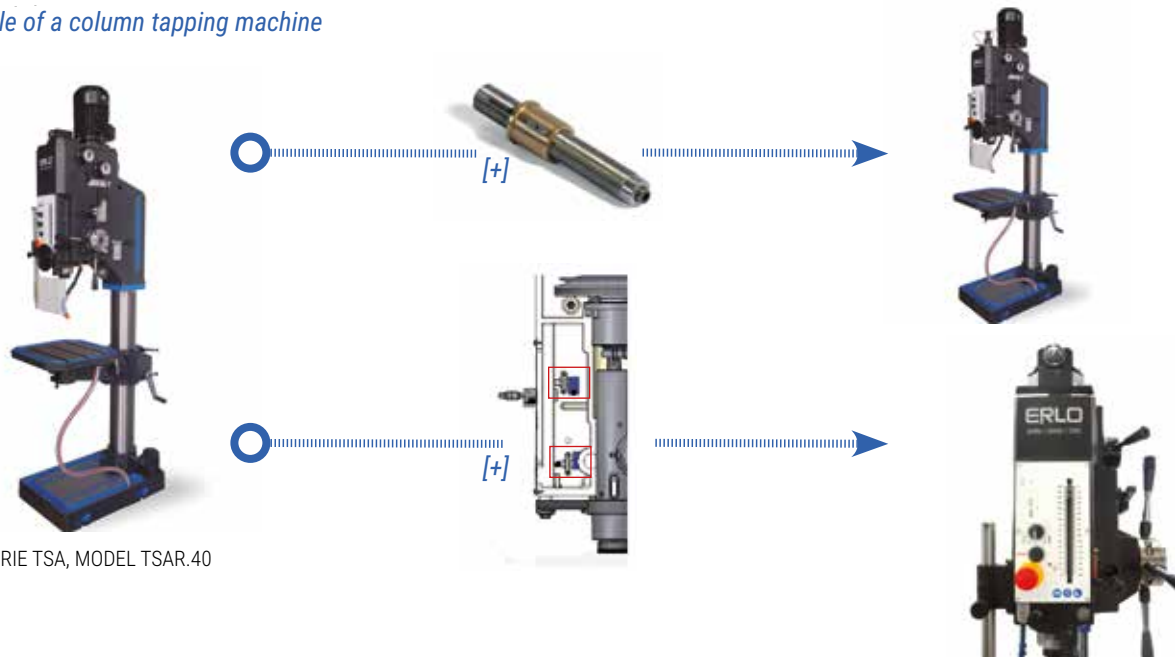

SERIE TSA, MODEL TSAR.40

### CHARACTERISTICS

- Feed mechanical automatic
- Transmission gears



# SERIE SH

## BENCH TYPE TAPPING MACHINES

- Automatic tapping feed
- V-belt drive
- Fixed table, displaceable and rotating headstock



### Standard equipment

- Table/base with "T" slots
- Adjustable depth end
- Lighting equipment
- Tool ejector
- Belt cover with stop micro
- 1 lead screw included, pitch to be determined
- Tapping cycle selection (1 cycle / continuous cycle)
- Automatic or manual tapping selection
- Adjustable ends and micros, for depth, turning and stop
- Bracking device for variator
- Emergency push button
- Main switch
- Turning sense selector
- Electrical equipment at low voltage
- Electrical equipment in a separate cabinet
- Drill guard with stop micro
- CE norms



**SH.30**

\* The base cabinet and the coolant equipment are extra equipment, not included in the tapping machine price

### Extra Equipment

	CODE
V - FRONTAL WHEEL FOR FINE SENSITIVE FEED	10020
LBC - DEPTH DIGITAL READER	10022
HGP-S - LEAD SCREW, SPECIAL PITCH	10075
HGP - LEAD SCREW, STANDARD PITCH	10080
PKB - BASE CABINET WITH DOOR AND SHELVES	10082
PKC - BASE CABINET (ONLY FOR MODELS WITH INTERMEDIATE TABLE)	10084
MIF - FIXED INTERMEDIATE TABLE	10087
MIG - ROTATING INTERMEDIATE TABLE	10088
CC - CYCLES COUNTER (FOR MACHINES WITH HIDROBLOCK)	10085
SC - COLUMN SUPPLEMENT 200 MM.	10110
ERB - COOLANT EQUIPMENT - SR	91118

\* In machines with intermediate table, the base cabinet has not the drawer (ref. PKC)

# Characteristics

**SH.18**

**SH.30**

TAPPING CAPACITY IN STEEL OF 70 Kg.	M14	M25
TRANSMISSION	V-BELT	
SPEED NUMBER AND RANGE (WITHOUT VARIATOR) 50 Hz.	(10) 245 - 355 - 490 - 710 - 835 - 1.240 - 1.670 - 2.000 - 2.480 - 4.000 rpm.	
DRILLING FEED	MANUAL	
MAIN MOTOR POWER MOTOR 1000 rpm.	1,5 HP	2 HP
SPINDLE CONE	MT3	
MAXIMUM TAPPING DEPTH	90 mm	
DISTANCE SPINDLE-COLUMN	250 mm	
DISTANCE SPINDLE-TABLE (MODELS WITHOUT COOLANT)	Min. 155 mm/ Max. 485 mm	
DISTANCE SPINDLE-TABLE (MODELS WITH COOLANT)	Min. 225 mm/ Max. 555 mm	
COLUMN DIAMETER	Ø100 mm	
DIMENSIONS OF THE TABLE/BASE (WITHOUT COOLANT)	270x270 mm	
DIMENSIONS OF THE TABLE/BASE (WITH COOLANT)	316x288 mm	
WEIGHT: NET / GROSS Kg. WITH BASE CABINET	230 / 250 Kg.	
PACKAGING DIMENSIONS AND VOLUME WITH BASE CABINET	0,89x0,64x1,35 / 0,77 m <sup>3</sup>	

# Dimensions

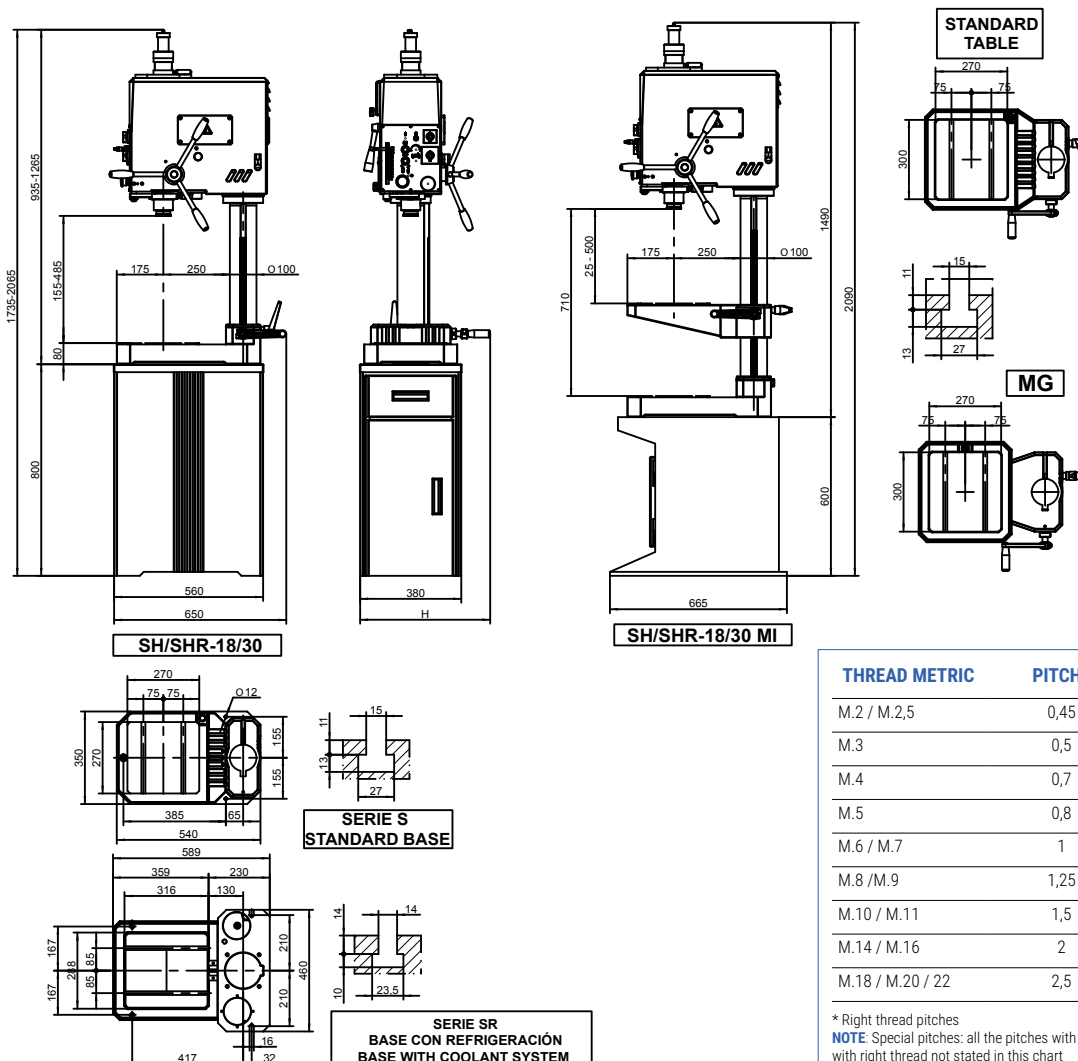

THREAD METRIC	PITCH*	PITCH WITHWORTH
M.2 / M.2,5	0,45	12H*
M.3	0,5	14H*
M.4	0,7	16H*
M.5	0,8	18H*
M.6 / M.7	1	20H*
M.8 / M.9	1,25	24H*
M.10 / M.11	1,5	
M.14 / M.16	2	
M.18 / M.20 / 22	2,5	

\* Right thread pitches  
**NOTE:** Special pitches: all the pitches with left thread and the pitches with right thread not stated in this chart

# SERIE SHE-SHEA

## BENCH TYPE TAPPING MACHINES

- Automatic tapping feed
- Geared drive
- Fixed table, displaceable and rotating headstock



## Standard equipment

- Table/base with "T" slots
- Adjustable depth end
- Lighting equipment
- Tool ejector
- 1 lead screw included, pitch to be determined
- Tapping cycle selection (1 cycle / continuous cycle)
- Automatic or manual tapping selection
- Adjustable ends and micros, for depth, turning and stop
- Bracking device for variator
- Emergency push button
- Main switch
- Turning sense selector
- Electrical equipment at low voltage
- Electrical equipment in a separate cabinet
- Drill guard with stop micro
- CE norms



**SHE.30**

\* The base cabinet and the coolant equipment are extra equipment, not included in the tapping machine price

## Extra Equipment

	CODE
V - FRONTAL WHEEL FOR FINE SENSITIVE FEED (ONLY FOR SHE SERIE)	10020
LBC - DEPTH DIGITAL READER	10022
HGP-S - LEAD SCREW, SPECIAL PITCH	10075
HGP - LEAD SCREW, STANDARD PITCH	10080
PKB - BASE CABINET WITH DOOR AND SHELVES	10082
PKC - BASE CABINET (ONLY FOR MODELS WITH INTERMEDIATE TABLE)	10084
MIF - FIXED INTERMEDIATE TABLE	10087
MIG - ROTATING INTERMEDIATE TABLE	10088
CC - CYCLES COUNTER (FOR MACHINES WITH HIDROBLOCK)	10085
SC - COLUMN SUPPLEMENT 200 MM.	10110
ERB - COOLANT EQUIPMENT	91118

\* In machines with intermediate table, the base cabinet has not the drawer (ref. PKC)

# Characteristics

	<b>SHE.30</b>	<b>SHEA.30</b>
TAPPING CAPACITY IN STEEL OF 70 Kg.	M25	M25
TRANSMISSION	GEARS (Hardened and ground)	
SPEED NUMBER AND RANGE (WITHOUT VARIATOR)	(8) 65 - 125 - 185 - 365 - 540 - 1.055 - 1.560 - 3.060 rpm.	
DRILLING FEED	MANUAL	AUTOMATIC
NUMBER AND RANGE OF FEEDS	-	(2) 0,10-0,20
MAIN MOTOR POWER MOTOR 1500 rpm.	2 HP	
SPINDLE CONE	MT3	
MAXIMUM TAPPING DEPTH	90 mm	
DISTANCE SPINDLE-COLUMN	250 mm	
DISTANCE SPINDLE-TABLE (MODELS WITHOUT COOLANT)	Min. 155 / Max. 485 mm	
DISTANCE SPINDLE-TABLE (MODELS WITH COOLANT)	Min. 225 / max. 555 mm	
COLUMN DIAMETER	Ø100 mm	
DIMENSIONS OF THE TABLE/BASE (WITHOUT COOLANT)	270x270 mm	
DIMENSIONS OF THE TABLE/BASE (WITH COOLANT)	316x288 mm	
WEIGHT: NET / GROSS Kg. WITH BASE CABINET	290 / 340 Kg.	
PACKAGING DIMENSIONS AND VOLUME WITH BASE CABINET	0,89x0,64x1,35 / 0,77 m <sup>3</sup>	

# Dimensions

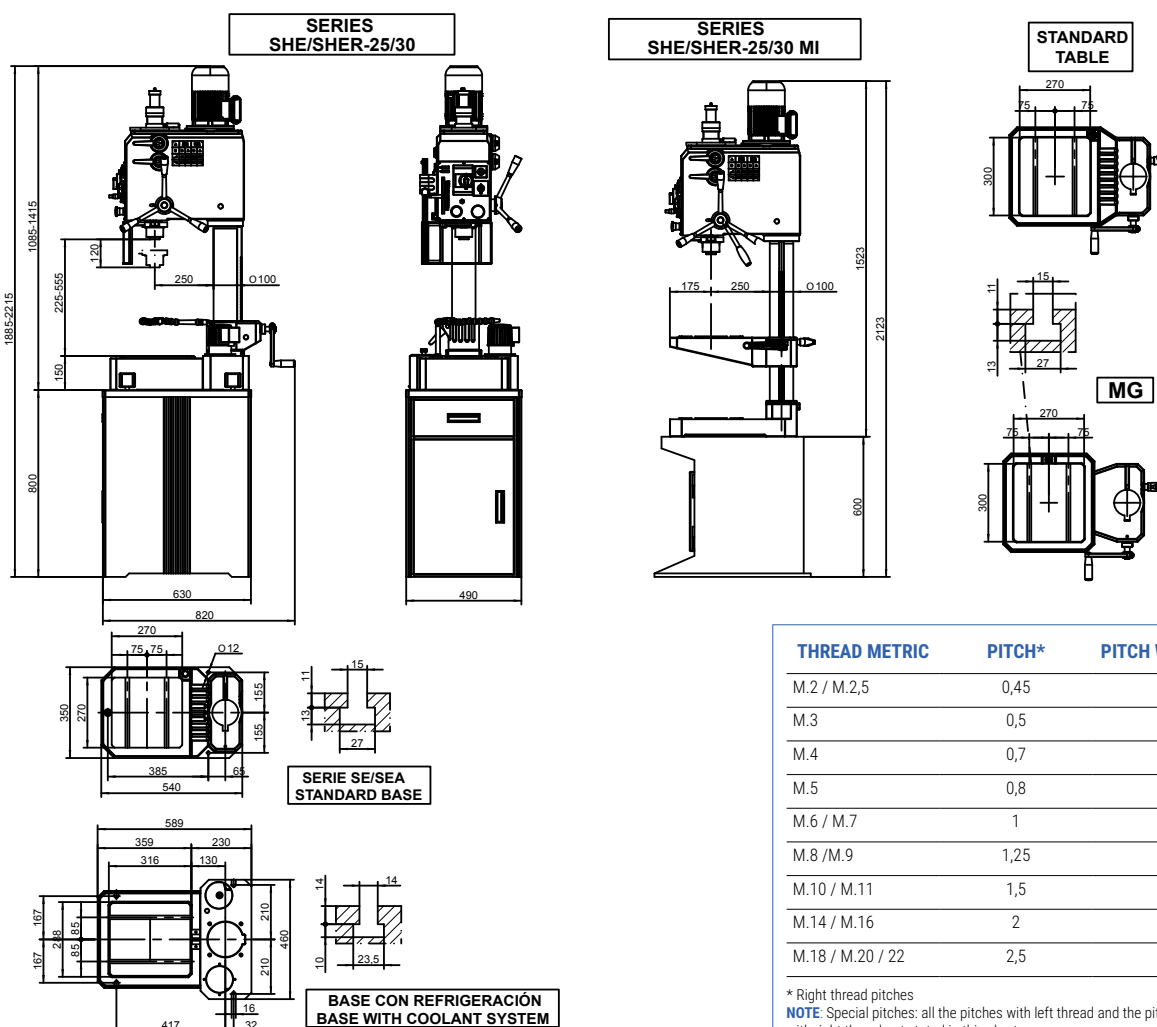

THREAD METRIC	PITCH*	PITCH WITHWORTH
M.2 / M.2,5	0,45	12H*
M.3	0,5	14H*
M.4	0,7	16H*
M.5	0,8	18H*
M.6 / M.7	1	20H*
M.8 / M.9	1,25	24H*
M.10 / M.11	1,5	
M.14 / M.16	2	
M.18 / M.20 / 22	2,5	

\* Right thread pitches  
**NOTE:** Special pitches: all the pitches with left thread and the pitches with right thread not stated in this chart

# SERIE FT

## BENCH TYPE TAPPING MACHINES

- Manual feed
- Electronic variator

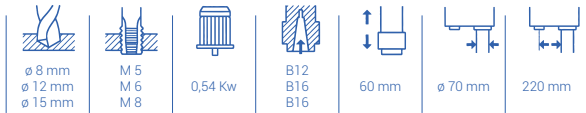

### Standard equipment

- Digital multifunction screen with:
  - Speed adjust and viewer
  - Depth viewer
  - Selector drilling/tapping
  - Button to set up 0 position
- Lighting equipment
- Magnetothermic switch
- Emergency push stop
- Drill guard with stop micro

NOTE: Base cabinet with door and shelves is optional equipment.



FT-1

### Extra Equipment

	CODE
PKE - BASE CABINET WITH DOOR AND SHELVES	250208
PCR.B12 - DRILL CHUCK CAPACITY 0,5/8 MM. B12, ACCURACY OF CONCENTRICITY: 0,20 MM	285103
PCRS.B12 - KEYLESS DRILL CHUCK (0,5-6 MM) B12, ACCURACY OF CONCENTRICITY: 0,05 MM	285104
PCRS.B16 - KEYLESS DRILL CHUCK (1-13 MM) B16, ACCURACY OF CONCENTRICITY: 0,30 MM (ONLY FOR MODEL FT-6)	285133
PNR.4-12 - TAP HOLDER FOR M4-M12, B16	285109
MF - FIXED BASE VICE, OPENING 95 MM.	281296
MIF - FIXED INTERMEDIATE TABLE (STANDARD IN FT-4 MODELS)	290521

## Characteristics

	FT-1	FT-6	FT-4
DRILLING CAPACITY	8 mm	12 mm	15 mm
CONTINUOUS DRILLING CAPACITY	6 mm	10 mm	13 mm
TAPPING CAPACITY	M5	M6	M8
SPINDLE CONE	B12	B16	B16
VARIABLE SPEED RANGE	100-10000 rpm.	60-6000 rpm.	40-4000 rpm.
VOLTAGE MOTOR / POWER - SINGLE PHASE	230V. / 0,54 kW	230V/0,54 kW	230V/0,54kW
VARIATOR TYPE:	ELECTRONIC	ELECTRONIC	ELECTRONIC
DRILLING DEPTH	60 mm	60 mm	60 mm
DISTANCE SPINDLE NOSE TO COLUMN	220 mm	220 mm	220 mm
DISTANCE SPINDLE-TABLE	140 mm	140 mm	Min. 85/Max. 370 mm
DISTANCE SPINDLE-BASE	315 mm	315 mm	420 mm
COLUMN DIAMETER	70 mm	70 mm	70 mm
NUMBER OF "T" SLOTS	2 CROSS SLOTS	2 CROSS SLOTS	2 PARALLELS SLOTS
DISTANCE BETWEEN SLOTS	N/A	N/A	125 mm
FEED	MANUAL	MANUAL	MANUAL
HEADSTOCK HEIGHT ADJUSTMENT	MANUAL	MANUAL	N/A
TABLE HEIGHT ADJUSTMENT	N/A	N/A	BY RACK
TABLE DIMENSIONS (WIDTH X HEIGHT)	300x250 mm	300x250 mm	300x250 mm
DIMENSIONS	320x450x830 mm	320x450x830 mm	440x450x860 mm
NET WEIGHT	44 Kgr.	44 Kgr.	62 Kgr.

## Dimensions

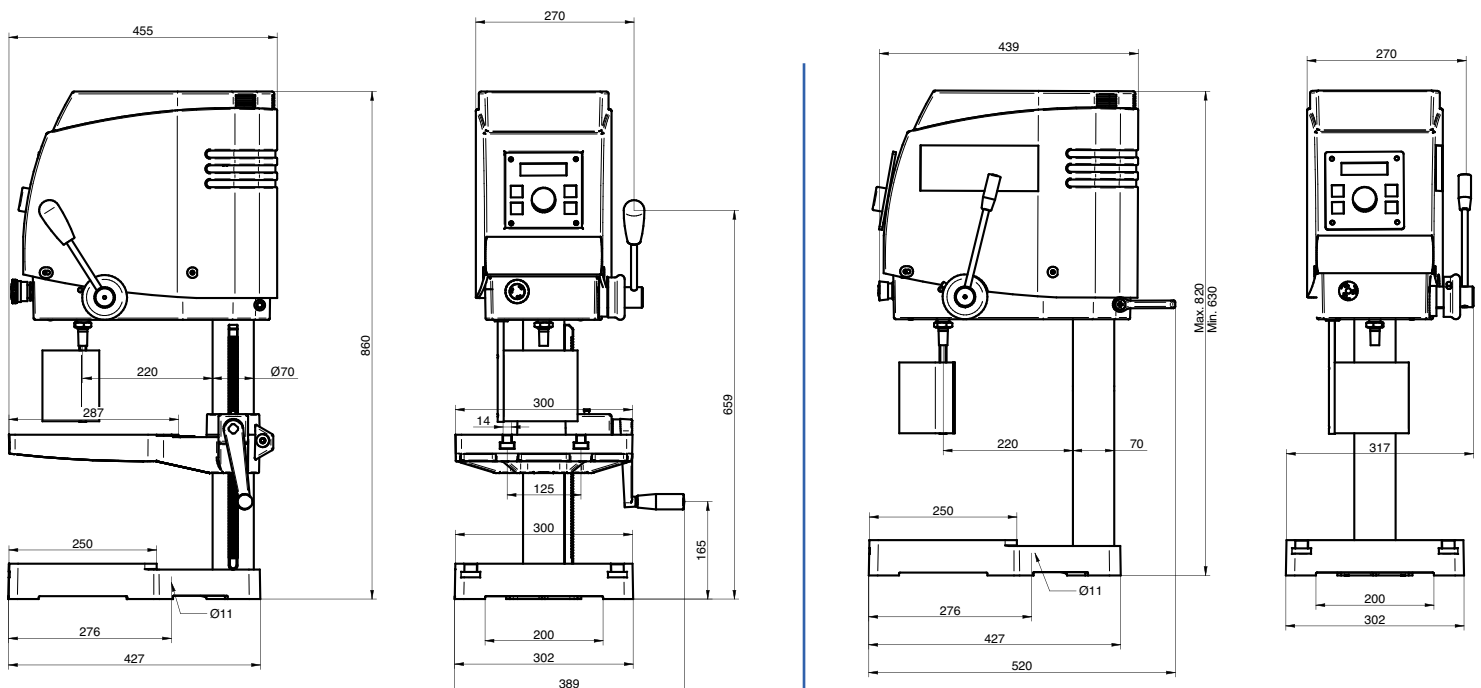

FT-4

FT-1 / FT-6

# SERIE C

## COLUMN DRILLING MACHINES

- Manual feed
- V-belt drive
- Displaceable table and fixed headstock

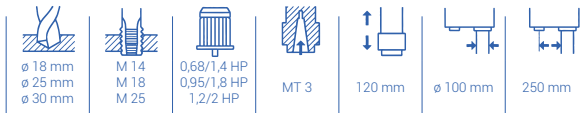

## Standard equipment

- Adjustable depth end
- Lighting equipment
- Tool ejector
- Belt cover with stop micro
- Motor guard and emergency push button
- Emergency push button
- Main switch
- Turning sense selector
- Electrical equipment at low voltage
- Electrical equipment in a separate cabinet
- Drill guard with stop micro
- Fixed table
- CE norms



**C.18**

## Extra Equipment

	CODE
V - FRONTAL WHEEL FOR FINE SENSITIVE FEED	10020
TAK - SPEED DIGITAL READER (FOR MODELS WITH ELECTRONIC VARIATOR)	10021
LBC - DEPTH DIGITAL READER	10022
VE - EXTRA PRICE FOR ELECTRONIC VARIATOR	10023
IR/RS - MANUAL TAPPING SYSTEM IR/RS	10042
IR/RS (VE) - MANUAL TAPPING SYSTEM IR/RS (FOR MODELS WITH VARIATOR)	10043
RHP - AUTOMATIC TAPPING SYSTEM BY LEAD SCREW (INCLUDES ONE TAPPING PITCH)	20070
MG - ROTATING TABLE	20082
CC - CYCLES COUNTER (FOR MACHINES WITH HIDROBLOCK)	10085
SC - COLUMN SUPPLEMENT 200 MM.	10110
HB - EXTRA PRICE FOR HYDROBLOCK EQUIPMENT	10120
ERB - COOLANT EQUIPMENT	91118



# Characteristics

	<b>C.18</b>	<b>C.25</b>	<b>C.30</b>
DRILLING CAPACITY IN STEEL OF 70 Kg. (mm)	18	25	30
TAPPING CAPACITY IN STEEL OF 70 Kg.	M14	M18	M25
TRANSMISSION	V-BELT		
SPEED NUMBER AND RANGE (WITHOUT VARIATOR) 50 HZ.	(10) 245 - 355 - 490 - 710 - 835 - 1.240 - 1.670 - 2.000 - 2.480 - 4.000 rpm.		
SPEED NUMBER AND RANGE (WITH VARIATOR)	VARIABLE A) 120-760 B) 170-1100 C) 400-2580 D) 600-3800 E) 950-6000 rpm.		
FEED	MANUAL		
MAIN MOTOR POWER (WITHOUT VARIATOR) MOTOR 750/1500 rpm.	0,68/1,4 HP	0,95/1,8 HP	1,2/2 HP
MAIN MOTOR POWER (WITH VARIATOR) MOTOR 1000 rpm.	1,5 HP	2 HP	2 HP
SPINDLE CONE	MT.3		
SPINDLE STROKE	120 mm		
SPINDLE STROKE WITH HYDROBLOCK	90 mm		
DISTANCE SPINDLE-COLUMN	250 mm		
DISTANCE SPINDLE-TABLE	Min. 85 mm/ Max. 635 mm		
DISTANCE SPINDLE-BASE	1195 mm		
COLUMN DIAMETER	Ø100 mm		
DIMENSIONS OF THE TABLE (WITH 2 T SLOTS)	270x300 mm		
DIMENSIONS OF THE BASE WITHOUT T SLOTS (WITHOUT COOLANT)	600x380 mm		
DIMENSIONS OF THE BASE WITH 2 T SLOTS (WITH COOLANT)	665x400 mm		
WEIGHT: NET / GROSS Kg.	260/320 Kg.		
PACKAGING DIMENSIONS AND VOLUME	2,11x0,57x0,8 / 0,97 m <sup>3</sup>		

# Dimensions

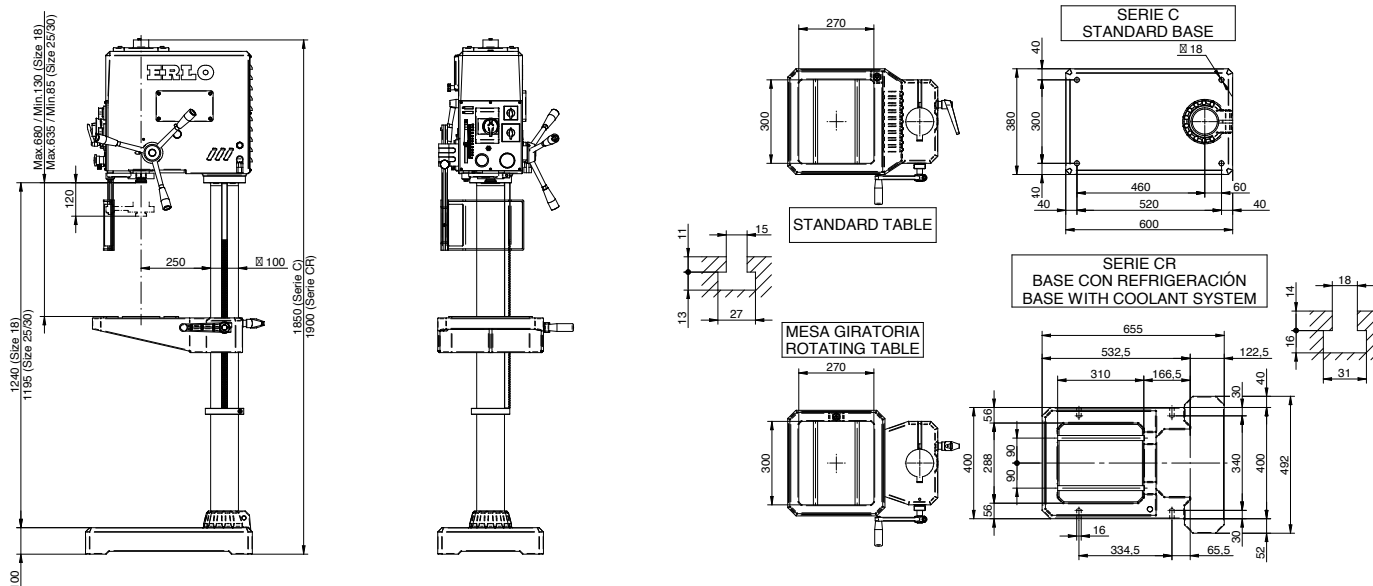

# SERIE TS-TSA.25-30

## COLUMN DRILLING MACHINES

- Manual feed (serie TS) and automatic feed (serie TSA)
- Geared drive
- Displaceable table and fixed headstock



## Standard equipment

- Adjustable depth end
- Lighting equipment
- Tool ejector
- Motor guard and emergency push button
- Main switch
- Turning sense selector
- Electrical equipment at low voltage
- Electrical equipment in a separate cabinet
- Drill guard with stop micro
- Fixed table
- CE norms



TS.25

## Extra Equipment

	CODE
V - FRONTAL WHEEL FOR FINE SENSITIVE FEED (ONLY FOR TS SERIE)	10020
TAK - SPEED DIGITAL READER (FOR MODELS WITH ELECTRONIC VARIATOR)	10021
LBC - DEPTH DIGITAL READER	10022
VE - EXTRA PRICE FOR ELECTRONIC VARIATOR	10023
IR/RS - MANUAL TAPPING SYSTEM IR/RS	10042
IR/RS (VE) - MANUAL TAPPING SYSTEM IR/RS (FOR MODELS WITH VARIATOR)	10043
RHP - AUTOMATIC TAPPING SYSTEM BY LEAD SCREW (INCLUDES ONE TAPPING PITCH)	20070
MG - ROTATING TABLE	20082
CC - CYCLES COUNTER (FOR MACHINES WITH HIDROBLOCK)	10085
SC - COLUMN SUPPLEMENT 200 MM.	10110
HB - EXTRA PRICE FOR HYDROBLOCK EQUIPMENT (ONLY FOR TS SERIE)	10120
ERB - COOLANT EQUIPMENT	91118

# Characteristics

	TS.25	TS.30	TSA.25	TSA.30
DRILLING CAPACITY IN STEEL OF 70 Kg. (mm)	25	30	25	30
TAPPING CAPACITY IN STEEL OF 70 Kg.	M22	M25	M22	M25
TRANSMISSION	GEARS (Hardened and grounded)			
SPEED NUMBER AND RANGE (WITHOUT VARIATOR)	(8) 65 - 125 - 185 - 365 - 540 - 1.055 - 1.560 - 3.060 rpm.			
SPEED NUMBER AND RANGE (WITH VARIATOR)	VARIABLE A )45-125 B) 125-370 C) 380-1070 D) 1100-3100 rpm.			
FEED	MANUAL	MANUAL	AUTOMATIC	AUTOMATIC
NUMBER AND RANGE OF FEEDS	-	-	(2) 0,10-0,20	(2) 0,10-0,20
MAIN MOTOR POWER (WITHOUT VARIATOR) MOTOR 1500/3000 rpm.	1,1/1,6 HP	1,5/1,9 HP	1,1/1,6 HP	1,5/1,9 HP
MAIN MOTOR POWER (WITH VARIATOR) MOTOR 1500 rpm.				2 HP
SPINDLE CONE				MT.3
SPINDLE STROKE				120 mm
SPINDLE STROKE WITH HYDROBLOCK (SERIE TS)	90 mm	90 mm	-	-
DISTANCE SPINDLE-COLUMN				250 mm
DISTANCE SPINDLE-TABLE				Mín. 170/Máx. 660 mm
DISTANCE SPINDLE-BASE				1216 mm
COLUMN DIAMETER				Ø100 mm
DIMENSIONS OF THE TABLE (WITH 2 T SLOTS)				270x300 mm
DIMENSIONS OF THE BASE WITHOUT T SLOTS (WITHOUT COOLANT)				600x380 mm
DIMENSIONS OF THE BASE WITH T SLOTS (WITH COOLANT)				665x400 mm
WEIGHT: NET / GROSS Kg.				260 / 320 Kg.
PACKAGING DIMENSIONS AND VOLUME				2,2x0,6x0,9 / 1,19 m <sup>3</sup>

# Dimensions

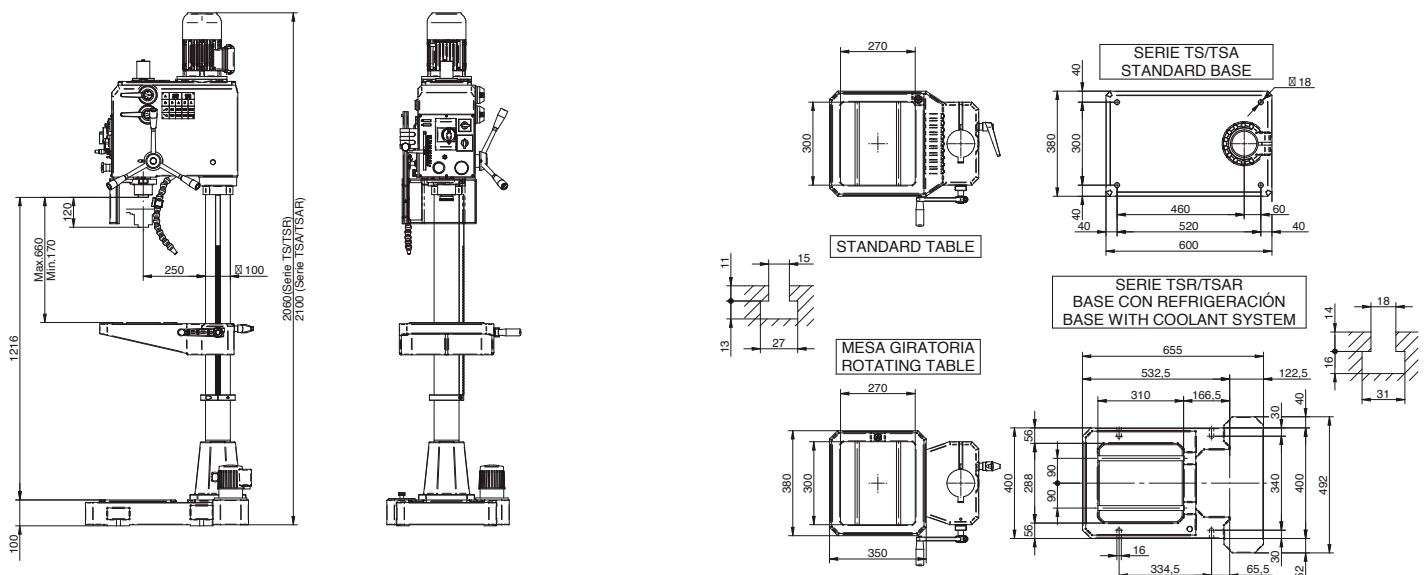

# SERIE TSA-TSE.32-35

## COLUMN DRILLING MACHINES

- Automatic feed, mechanical clutch (serie TSA) and electromagnetic clutch (serie TSE)
- Geared drive
- Displaceable table and fixed headstock



## Standard equipment

- Adjustable depth end
- Lighting equipment
- Tool ejector
- Motor guard and emergency push button
- Main switch
- Turning sense selector
- Electrical equipment at low voltage
- Electrical equipment in a separate cabinet
- Drill guard with stop micro
- Fixed table
- CE norms



TSA.32

## Extra Equipment

	CODE
V - FRONTAL WHEEL FOR FINE SENSITIVE FEED	10020
VE - EXTRA PRICE FOR SPEEDS ELECTRONIC VARIATOR	10021
TAK - SPEEDS DIGITAL READER (FOR MODELS WITH VARIATOR)	10022
LBC - DEPTH DIGITAL READER	10023
IR/RS - MANUAL TAPPING SYSTEM IR/RS	10042
IR/RS (VE) - MANUAL TAPPING SYSTEM IR/RS (FOR MODELS WITH VARIATOR)	10043
RPF - AUTOMATIC TAPPING SYSTEM BY LEAD SCREW (INCLUDES ONE TAPPING PITCH)	20070
MGI - ROTATING AND TILTING TABLE	30084
MGM - REVERSIBLE ROTATING TABLE WITH VICE	20087
SC - COLUMN SUPPLEMENT 200 MM.	10110
ACNL - RAPID APPROACH AND RETURN WITH PNEUMATIC COUNTERWEIGHT (FOR TSE SERIE)	30140
CI - INTEGRAL TUBES DRILLING CYCLE/PROFILES AND INTERMITTANCES (FOR TSE SERIE)	30145
ERB - COOLANT EQUIPMENT IN THE BASE	91118

# Characteristics

	TSA.32	TSA.35	TSE.32	TSE.35
DRILLING CAPACITY IN STEEL OF 70 Kg. (mm)	32	35	32	35
TAPPING CAPACITY IN STEEL OF 70 Kg.	M28	M30	M28	M30
TRANSMISSION	GEARS (Hardened and grounded)			
SPEED NUMBER AND RANGE (WITHOUT VARIATOR)	(8) 75 - 150 - 235 - 325 - 470 - 650 - 1.050 - 2.100 rpm.			
SPEED NUMBER AND RANGE (WITH VARIATOR)	VARIABLE A) 75 -175 B) 240 - 570 C) 330 - 780 D) 1060 - 2500 rpm			
FEED	AUTOMATIC			
NUMBER AND RANGE OF FEEDS	(3) 0,10-0,20-0,30			
CLUTCH	(3) 0,10-0,20-0,30		ELECTROMAGNETIC	
MAIN MOTOR POWER (WITHOUT VARIATOR) MOTOR 750/1500 rpm.	1/1,5 HP	1,2/2 HP	1/1,5 HP	1,2/2 HP
MAIN MOTOR POWER (WITH VARIATOR) MOTOR 1500 rpm.				2 HP
SPINDLE CONE	MT.4			
SPINDLE STROKE	160 mm			
DISTANCE SPINDLE-COLUMN	300 mm			
DISTANCE SPINDLE-TABLE	Min. 70 / Max. 885			
DISTANCE SPINDLE-BASE	1.245 mm			
COLUMN DIAMETER	Ø125 mm			
DIMENSIONS OF THE TABLE WITH 3 T SLOTS	400x420 mm			
DIMENSIONS OF THE BASE WITHOUT T SLOTS (WITHOUT COOLANT)	400x655 mm			
DIMENSIONS OF THE BASE WITH T SLOTS (WITH COOLANT)	492x655 mm			
WEIGHT: NET / GROSS Kg.	300 / 400 Kg.			
PACKAGING DIMENSIONS AND VOLUME	2,37x0,6x0,96 / 1,37 m <sup>3</sup>			

# Dimensions

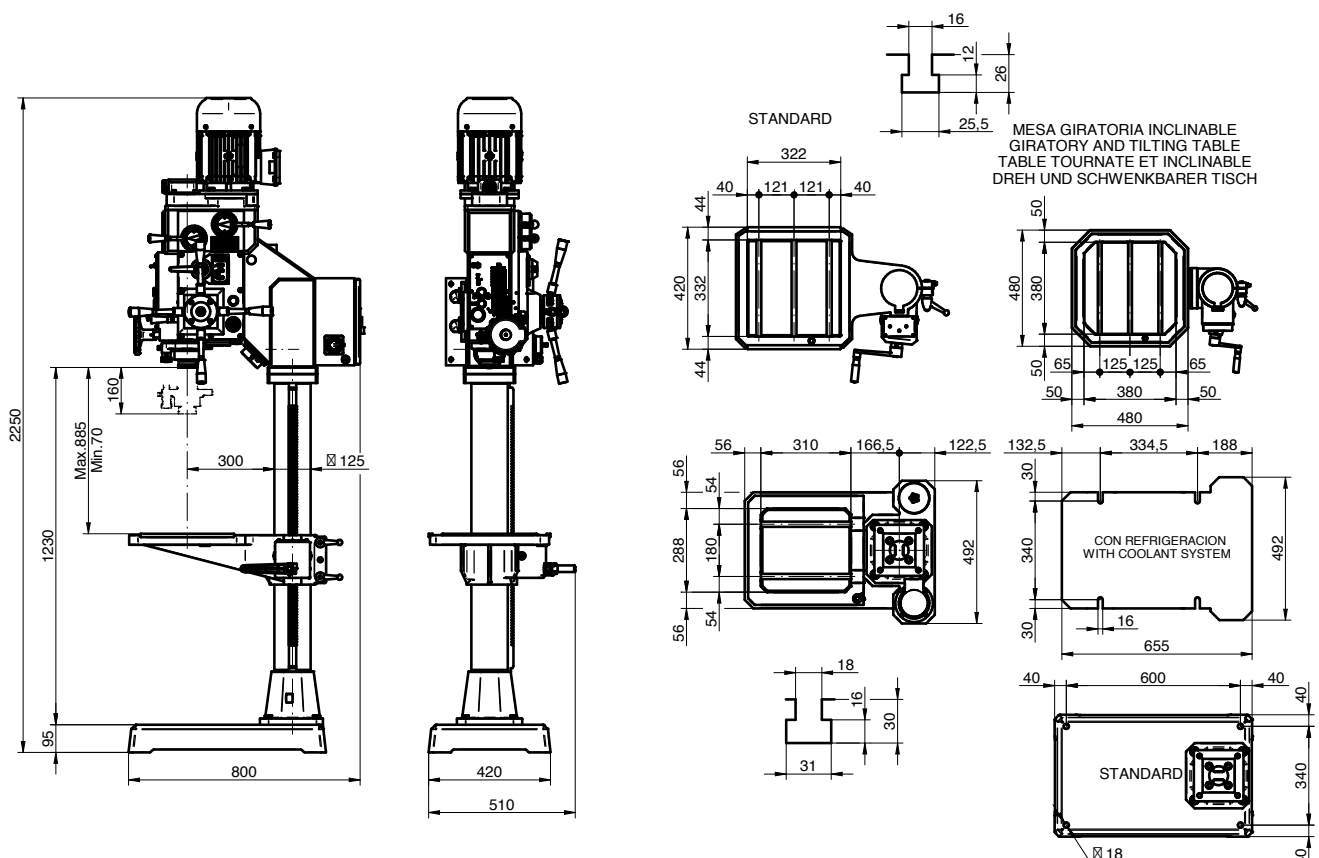

# SERIE TSA-TSE.40-45

## COLUMN DRILLING MACHINES

- Automatic feed, mechanical clutch (serie TSA) and electromagnetic clutch (serie TSE)
- Geared drive
- Displaceable table and fixed headstock



## Standard equipment

- Adjustable depth end
- Lighting equipment
- Coolant equipment
- Rotating and tilting table
- Frontal wheel for fine sensitive feed
- Tool ejector
- Motor guard
- Emergency push button
- Main switch
- Turning sense selector
- Electrical equipment at low voltage
- Electrical equipment in a separate cabinet
- Drill guard with stop micro
- CE norms



TSA.40

## Extra Equipment

	CODE
VE - EXTRA PRICE FOR SPEEDS ELECTRONIC VARIATOR	10021
TAK - SPEEDS DIGITAL READER (FOR MODELS WITH VARIATOR)	10023
LBC - DEPTH DIGITAL READER	10022
IR/RS - MANUAL TAPPING SYSTEM IR/RS	10042
IR/RS (VE) - MANUAL TAPPING SYSTEM IR/RS (FOR MODELS WITH VARIATOR)	10043
RPF - AUTOMATIC TAPPING SYSTEM BY LEAD SCREW (INCLUDES ONE TAPPING PITCH)	30070
SC - COLUMN SUPPLEMENT 200 MM.	30110
ACNL - RAPID APPROACH AND RETURN WITH PNEUMATIC COUNTERWEIGHT (FOR TSE SERIE)	30140
CI - INTEGRAL TUBES DRILLING CYCLE/PROFILES AND INTERMITTANCES (FOR TSE SERIE)	30145

# Characteristics

	TSA.40	TSA.45	TSE.40	TSE.45
DRILLING CAPACITY IN STEEL OF 70 Kg. (mm)	40	45	40	45
TAPPING CAPACITY IN STEEL OF 70 Kg.	M32	M35	M32	M35
TRANSMISSION	GEARS (Hardened and grounded)			
SPEED NUMBER AND RANGE (WITHOUT VARIATOR)	(8) 93 - 152 - 204 - 298 - 443 - 695 - 970 - 1.420 rpm.			
SPEED NUMBER AND RANGE (WITH VARIATOR)	VARIABLE A) 45-145 B) 65-207 C)100-316 D) 144-460 E) 215-686 F) 307-985 G) 470-1500 H) 690-2200 rpm			
FEED	AUTOMATIC			
NUMBER AND RANGE OF FEEDS	(3) 0,10-0,18-0,24			
CLUTCH	MECHANIC (Automatic)		ELECTROMAGNETIC	
MAIN MOTOR POWER (WITHOUT VARIATOR) MOTOR 1500 rpm.	2 HP	3 HP	2 HP	3 HP
MAIN MOTOR POWER (WITH VARIATOR) MOTOR 1500 rpm.	3 HP			
SPINDLE CONE	CM.4			
SPINDLE STROKE	180 mm			
DISTANCE SPINDLE-COLUMN	350 mm			
DISTANCE SPINDLE-TABLE	Min. 95 / Max. 865			
DISTANCE SPINDLE-BASE	1.220 mm			
COLUMN DIAMETER	Ø150 mm			
DIMENSIONS OF THE TABLE WITH 3 T SLOTS	480x480 mm			
DIMENSIONS OF THE BASE WITH T SLOTS	480x755 mm			
ELECTRICAL EQUIPMENT IN A SEPARATE CABINET	NO			
WEIGHT: NET / GROSS Kg.	435 / 565 Kg.			
PACKAGING DIMENSIONS AND VOLUME	2,38x0,62x1,05 / 1,55 m <sup>3</sup>			



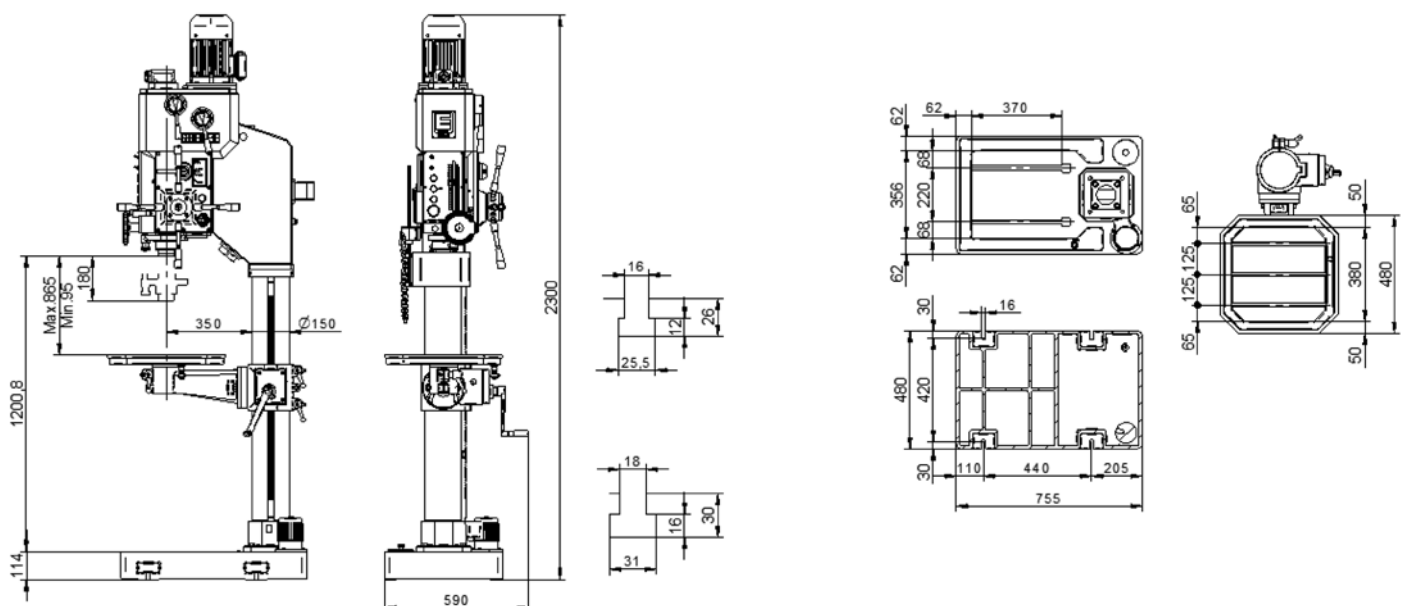



# Dimensions



# SERIE TCA-TCE

## COLUMN DRILLING MACHINES

- Automatic feed, mechanical clutch (serie TCA) and electromagnetic clutch (serie TCE)
- Geared drive
- Displaceable table and fixed headstock

						
ø 40 mm ø 50 mm ø 60 mm ø 70 mm	M 33 M 36 M 42 M 50	3HP 4HP 5,5HP 7,5HP	MT4 MT4 MT5 MT5	200 mm 230 mm 260 mm 260 mm	ø 175 mm ø 200 mm ø 220 mm ø 220 mm	360 mm 400 mm 420 mm 420 mm

## Standard equipment

- Hardened and high quality steel gears
- Speed plate and selecting levers on head
- Gear box lubrication by automatic pumps
- Machine base with coolant tank and pump
- Worklight
- Rotating and tilting table
- Automatic feed and cut-off by mechanic clutch (TCA) and by electromagnetic clutch (TCE)
- Frontal wheel for fine sensitive feed
- Depth scale and adjustable depth stop
- Automatic tool ejector
- Electric equipment integrated on machine's head
- Emergency stop push button
- Spindle reversing switch
- Safety drill guard with microswitch
- CE marks



**TCA.50**

## Extra Equipment

	CODE
IR/RS - MANUAL TAPPING SYSTEM IR/RS	10042
IR/RS (VE) - MANUAL TAPPING SYSTEM IR/RS (FOR MODELS WITH VARIATOR)	10043
RPF - AUTOMATIC TAPPING SYSTEM BY LEAD SCREW (INCLUDES ONE TAPPING PITCH)	30070
AR - REDUCED FEEDS (50% STANDARD RANGE)	40039
SC - COLUMN SUPPLEMENT 200 MM.	40070
VE - EXTRA PRICE FOR SPEED ELECTRONIC VARIATOR	40045
TAK - SPEEDS DIGITAL READER (FOR MODELS WITH VARIATOR)	40047
LBC - DEPTH DIGITAL READER	10022
ACNL - RAPID APPROACH AND RETURN WITH PNEUMATIC COUNTERWEIGHT (FOR TCE SERIE)	40100
CI - INTEGRAL CYCLE WITH ENCODER (FOR TCE SERIE)	40110



# Characteristics

	TCA.40	TCA.50	TCE.40	TCE.50	TCE.60	TCE.70
DRILLING CAPACITY IN STEEL OF 70 Kg. (mm)	40	50	40	50	60	70
TAPPING CAPACITY IN STEEL OF 70 Kg.	M33	M36	M33	M36	M42	M50
TRANSMISSION	GEARS (Hardened and ground)					
SPEED NUMBER AND RANGE (WITHOUT VARIATOR)	(9) 61-85-123-191-269-390-574-806-1169 rpm.	(9) 54-75-109-169-237-344-507-712-1032 rpm.	(9) 61-85-123-191-269-390-574-806-1169 rpm.	(9) 54-75-109-169-237-344-507-712-1032 rpm.	(12) 64-80-106-138-199-248-328-429-561-701-926-1210 rpm.	(12) 51-64-84-110-158-198-262-342-447-559-738-966 rpm.
FEED	AUTOMATIC	AUTOMATIC	AUTOMATIC	AUTOMATIC	AUTOMATIC	AUTOMATIC
SPEED NUMBER AND RANGE	(4) 0,10-0,20-0,30-0,40			(6) 0,1-0,2-0,3-0,4-0,5-0,6		
CLUTCH	MECHANIC (Automatic)		ELECTROMAGNETIC		ELECTROMAGNETIC	
MAIN MOTOR POWER, MOTOR 1500 rpm.	3 HP	4 HP	3 HP	4 HP	5,5 HP	7,5 HP
SPINDLE CONE	MT.4	MT.4	MT.4	MT.4	MT.5	MT.5
SPINDLE STROKE	200 mm	230 mm	200 mm	230 mm	260 mm	260 mm
DISTANCE SPINDLE-COLUMN	360 mm	400 mm	360 mm	400 mm	420 mm	420 mm
DISTANCE SPINDLE-TABLE	Min. 35/Max. 835	Min. 50/Max.850	Min. 35/Max. 835	Min. 50/Max.850	Min. 25/Max. 825	Min. 25/Max. 825
DISTANCE SPINDLE-BASE	1.240 mm	1.290 mm	1.240 mm	1.290 mm	1.270 mm	1.270 mm
COLUMN DIAMETER	Ø175 mm	Ø200 mm	Ø175 mm	Ø200 mm	Ø220 mm	Ø220 mm
DIMENSIONS OF THE TABLE WITH 3 T SLOTS	550x550 mm		550x550 mm		600x600 mm	
DIMENSIONS OF THE BASE WITH T SLOTS	950x550 mm	1060x600 mm	950x550 mm	1060x600 mm	1060x600 mm	1060x600 mm
WEIGHT: NET / GROSS Kg.	610/695	710/795	610/695	710/795	820/920	840/940
PACKAGING DIMENSIONS AND VOLUME	2,5x0,6x1,2 1,8 m <sup>3</sup>	2,6x0,6x1,2 1,88 m <sup>3</sup>	2,5x0,6x1,2 1,8 m <sup>3</sup>	2,6x0,6x1,2 1,88 m <sup>3</sup>	2,7x0,7x1,2 2,27 m <sup>3</sup>	2,7x0,7x1,2 2,27 m <sup>3</sup>

# Dimensions

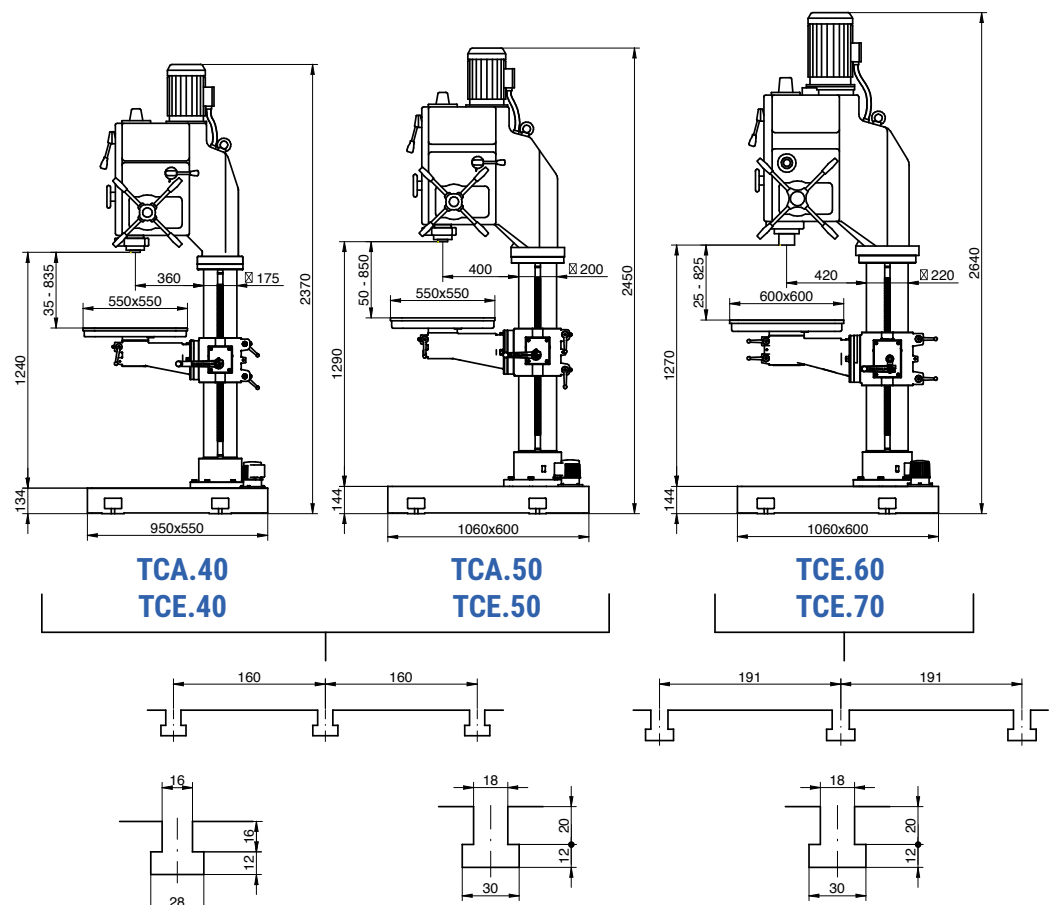

# SERIE TH

## COLUMN DRILLING MACHINES

- Automatic feed, electromagnetic clutch
- Transmission: Belt/Gear
- Rotating and tilting table and fixed headstock



## Standard equipment

- Wide continuous speed range in 3 steps
- Speed plate and selecting levers on head front
- Mechanical speed variator in (THV models)
- Electronic speed variator in (THI models)
- Digital rpm counter in front (THI models)
- Gear box lubrication by automatic pump
- Machine base with coolant tank and pump
- Worklight
- MGI: Rotating and tilting table
- Automatic feed and cut-off by electromagnetic clutch
- Front hand wheel for feed work
- Depth scale and adjustable depth stop
- Automatic feed reversing system for tapping
- Automatic tool ejector
- Electric equipment integrated on machine's head
- Emergency STOP push button
- Spindle reversing switch
- Safety drill guard with microswitch
- CE mark



THI.50

## Extra Equipment

	CODE
LBC - DEPTH DIGITAL READER	50012
AR - REDUCED FEEDS (50% STANDARD RANGE)	40039

# Characteristics

	THV.40	THI.40	THV.50	THI.50
DRILLING CAPACITY IN STEEL ST 70 KG (MM)	40		50	
TAPPING CAPACITY IN CAS IRON 70 KG	M36		M42	
TRANSMISSION	BELT/GEAR			
SPEED RANGE WITH MOTOR AT 1500 RPM 50 HZ 3 PH	60 a 200 200 a 600 600 a 1500	30 a 300 90 a 900 190 a 1900	60 a 200 200 a 600 600 a 1500	30 a 300 90 a 900 190 a 1900
SPEED VARIATOR TYPE	Mechanic	Electronic	Mechanic	Electronic
FEED	AUTOMATIC BY ELECTROMAGNETIC CLUTCH			
NUMBER AND RANGE OF FEEDS	(4) 0,1-0,2-0,3-0,4			
CLUTCH	ELECTROMAGNETIC CLUTCH			
MAIN MOTOR POWER 1500RPM	4HP		5,5HP	
SPINDLE CONE	MT4			
SPINDLE STROKE	200 mm			
DISTANCE SPINDLE-COLUMN	360 mm			
DISTANCE HUSILLO-MESA	Min.55/Max.850			
DISTANCE SPINDLE-TABLE	1260 mm			
COLUMN DIAMETER	Ø175			
DIMENSIONS OF THE TABLE WITH 3 T SLOTS	550x550 mm			
DIMENSIONS OF THE BASE WITH T SLOTS	950x550 mm			
WEIGHT: NET/GROSS KG.	660/750		760/850	
PACKAGING DIMENSIONS AND VOLUME	2,2x0,7x1,2 1,7 m <sup>3</sup>		2,2x0,7x1,3 2,0 m <sup>3</sup>	

# Dimensions

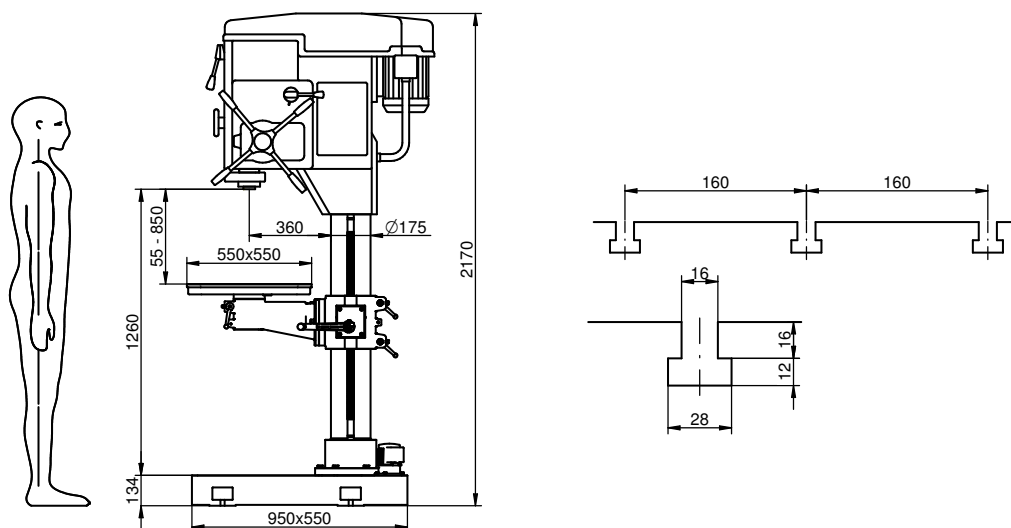

# SERIE V-VP

## PROFESSIONAL

- Manual feed (serie V.32 and V.40) - automatic feed (VP.40)
- V-belt drive (V.32), mechanical variator of conical pulleys (V.40 and VP.40)
- Displaceable table and fixed headstock



## Standard equipment

- Adjustable depth end
- Tool ejector
- Belt cover with stop micro
- Emergency push button
- Turning sense selector
- Electrical equipment at low voltage
- Drill guard with stop micro
- Fixed table
- CE norms



VP.40

## Extra Equipment

	CODE
L - LIGHTING EQUIPMENT	20010
IR/RS - MANUAL TAPPING SYSTEM IR/RS	10042
MG - ROTATING TABLE (FOR SERIE V.32)	20082
MGI - ROTATING AND TILTING TABLE (FOR SERIES V.40 AND VP.40)	30084
MGM - REVERSIBLE ROTATING TABLE WITH VICE (FOR SERIES V.40 AND VP.40)	20087
ERB - COOLANT EQUIPMENT IN THE BASE	91118

# Characteristics

	V.32	V.40	VP.40
DRILLING CAPACITY IN STEEL OF 70 Kg. (mm)	32	40	40
TAPPING CAPACITY IN STEEL OF 70 Kg.	M24	M32	M32
TRANSMISSION	V-BELT	MECHANICAL VARIATOR OF CONICAL PULLEYS	
SPEED NUMBER AND RANGE 50 HZ.	245-355-490-710-835-1240-1670-2000-2480-4000 rpm.		VARIABLE 80 - 1170 rpm.
FEED	MANUAL	MANUAL	AUTOMATIC
NUMBER AND FEED NUMBER	-	-	(2) 0,10-0,20
CLUTCH	-	-	MECHANIC
MAIN MOTOR POWER - 750/1500 rpm.	1,8/3,2 HP	1,8/3,2 HP	1,8/3,2 HP
SPINDLE CONE	MT3	MT4	MT4
SPINDLE STROKE	120 mm	150 mm	190 mm
DISTANCE SPINDLE-COLUMN	250 mm	300 mm	
DISTANCE SPINDLE-TABLE	Min. 85 mm/ Max. 635 mm	Min. 150 / Max. 950 mm	
DISTANCE SPINDLE-BASE	1195 mm	1310 mm	
COLUMN DIAMETER	Ø100 mm	Ø125 mm	
DIMENSIONS OF THE TABLE (WITH 2 T SLOTS)	270x300 mm	400x420 mm	
DIMENSIONS OF THE BASE WITHOUT T SLOTS (WITHOUT COOLANT)	600x380 mm	400x655 mm	
DIMENSIONS OF THE BASE WITH 2 T SLOTS (WITH COOLANT)	665x400 mm	492x655 mm	
WEIGHT: NET / GROSS Kg.	260 / 320 Kg.	260 / 320 Kg.	
PACKAGING DIMENSIONS AND VOLUME	2,11x0,57x0,8 / 0,97 m <sup>3</sup>	2,08x0,63x1,11 / 1,45 m <sup>3</sup>	

# Dimensions

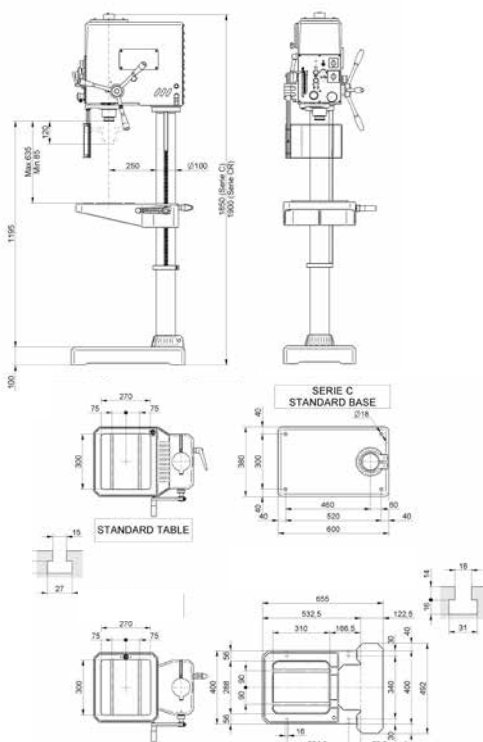

V.32

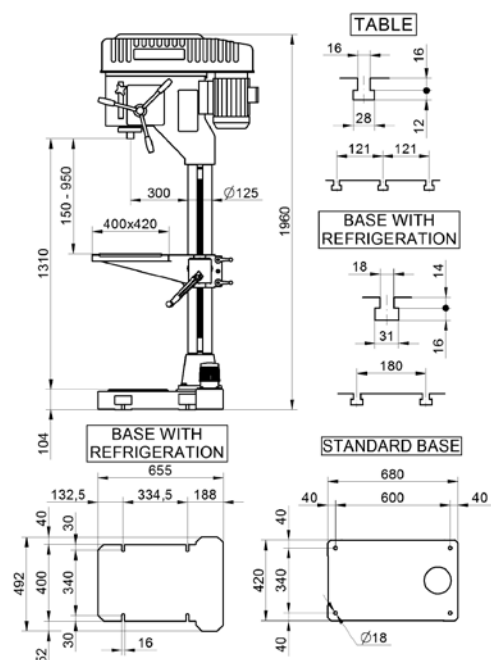

V.40/VP.40

# SERIE V-VP

## PROFESSIONAL

- Manual feed (serie V.35) - automatic feed (VP.35)
- V-belt drive
- Electronic variator and speed digital reader
- IR/RS manual tapping system



## Standard equipment

- Adjustable depth end
- Tool ejector
- Belt cover with stop micro
- Emergency push button
- Turning sense selector
- Electrical equipment at low voltage
- Drill guard with stop micro
- Fixed table
- CE norms



VP.35

## Extra Equipment

	CODE
L - LIGHTING EQUIPMENT	20010
MGI - ROTATING AND TILTING TABLE	30084
MGM - REVERSIBLE ROTATING TABLE WITH VICE	20087
ERB - COOLANT EQUIPMENT IN THE BASE	91118

# Characteristics

	V.35	VP.35
DRILLING CAPACITY IN STEEL OF 70 Kg. (mm)	35	35
TAPPING CAPACITY IN STEEL OF 70 Kg.	M27	M27
TRANSMISSION	ELECTRONIC BY SPEED VARIATOR AND BELTS	
SPEED NUMBER AND RANGE 50 HZ.	VARIABLE 100-2000 rpm.	
FEED	MANUAL	AUTOMATIC
NUMBER AND FEED NUMBER	-	(3) 0,10-0,20-0,30
CLUTCH	-	MECÁNICO
MAIN MOTOR POWER - 750/1500 rpm.	4 HP	4 HP
SPINDLE CONE	MT4	MT4
SPINDLE STROKE	150 mm	150 mm
DISTANCE SPINDLE-COLUMN	300 mm	300 mm
DISTANCE SPINDLE-TABLE	Min. 90 mm/ Max. 890 mm	Min. 90 mm/ Max. 890 mm
DISTANCE SPINDLE-BASE	1250 mm.	1250 mm.
COLUMN DIAMETER	Ø125 mm.	Ø125 mm.
DIMENSIONS OF THE TABLE (WITH 2 T SLOTS)	400x420 mm.	400x420 mm.
DIMENSIONS OF THE BASE WITHOUT T SLOTS (WITHOUT COOLANT)	400x655 mm	400x655 mm
DIMENSIONS OF THE BASE WITH 2 T SLOTS (WITH COOLANT)	492x655 mm	492x655 mm
WEIGHT: NET / GROSS Kg.	345 / 395 Kg.	360 / 410 Kg.
PACKAGING DIMENSIONS AND VOLUME	2,3x0,60x1,1 m – 1,5 m <sup>3</sup>	2,3x0,60x1,1 m – 1,5 m <sup>3</sup>

# Dimensiones

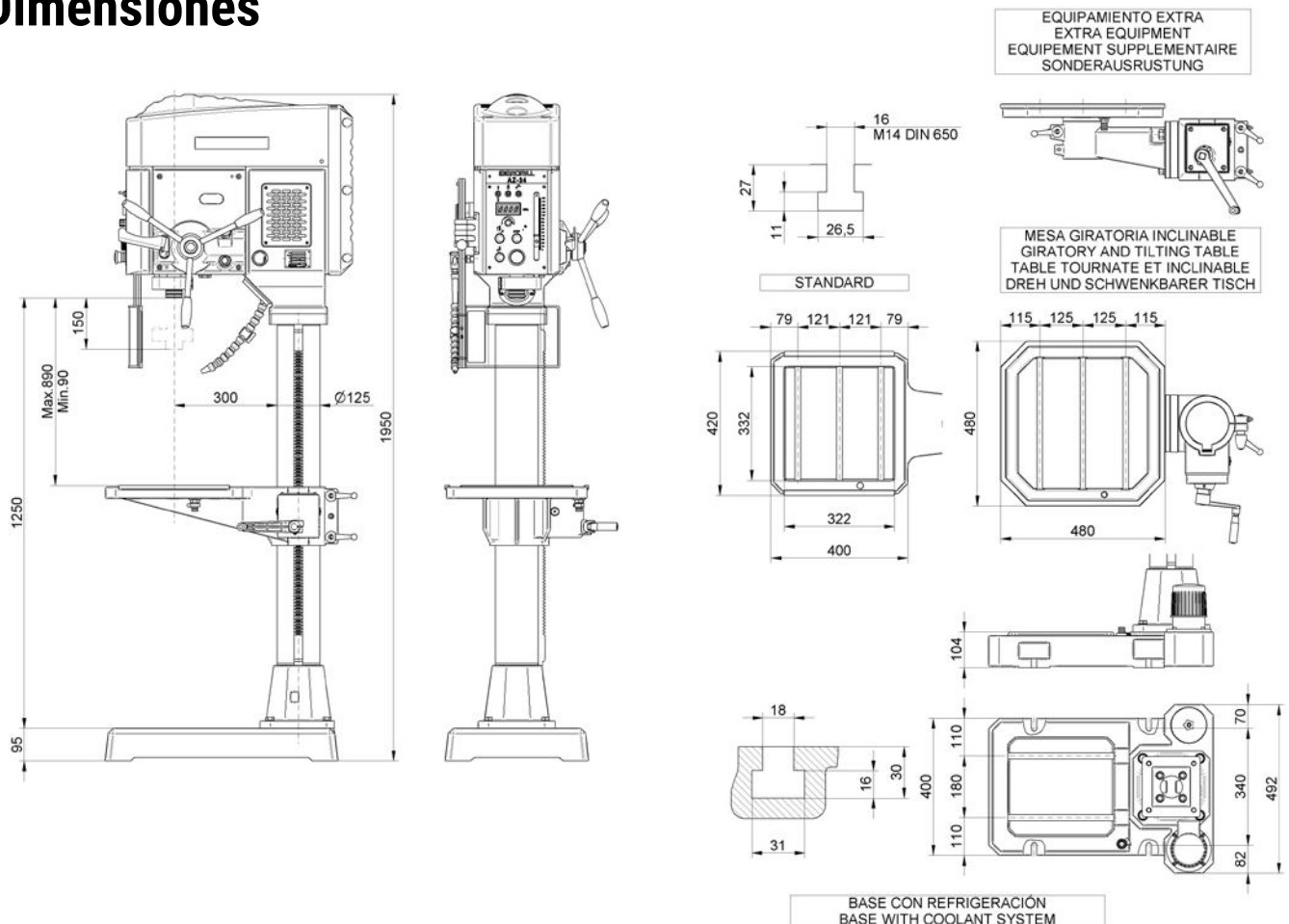

# SERIE G-GP.32

## PROFESSIONAL

- Manual feed (serie G.32) and automatic feed (serie GP.32)
- Geared drive
- Displaceable table and fixed headstock



## Standard equipment

- Adjustable depth end
- Tool ejector
- Emergency push button
- Turning sense selector
- Electrical equipment at low voltage
- Drill guard with stop micro
- Fixed table
- CE norms



GP.32

## Extra Equipment

	CODE
L - LIGHTING EQUIPMENT	20010
IR/RS - MANUAL TAPPING SYSTEM IR/RS	10042
MG - ROTATING TABLE	20082
ERB - COOLANT EQUIPMENT IN THE BASE	91118



# Characteristics

**G.32**

**GP.32**

DRILLING CAPACITY IN STEEL OF 70 Kg. (mm)	32	
TAPPING CAPACITY IN STEEL OF 70 Kg.	M24	
TRANSMISSION	GEARS (Hardened and grounded)	
SPEED NUMBER AND RANGE	65-125-185-365-540-1055-1560-3060 rpm.	
FEED	MANUAL	AUTOMATIC
NUMBER AND RANGE OF FEEDS	-	(3) 0,10-0,20-0,30
CLUTCH	-	MECHANIC
MAIN MOTOR POWER -1500/3000 rpm.	2/3 HP	
SPINDLE CONE	MT.3	
SPINDLE STROKE	120 mm	
DISTANCE SPINDLE-COLUMN	250 mm	
DISTANCE SPINDLE-TABLE	Min. 85 mm/ Max. 635 mm	
DISTANCE SPINDLE-BASE	1170 mm	
COLUMN DIAMETER	Ø100 mm	
DIMENSIONS OF THE TABLE (WITH 2 T SLOTS)	270x300 mm	
DIMENSIONS OF THE BASE WITHOUT T SLOTS (WITHOUT COOLANT)	600x380 mm	
DIMENSIONS OF THE BASE WITH T SLOTS (WITH COOLANT)	665x400 mm	
WEIGHT: NET / GROSS Kg.	260 / 320 Kg.	
PACKAGING DIMENSIONS AND VOLUME	2,11x0,57x0,8 / 0,97 m <sup>3</sup>	2,14x0,6x0,8 / 1,02 m <sup>3</sup>

# Dimensions

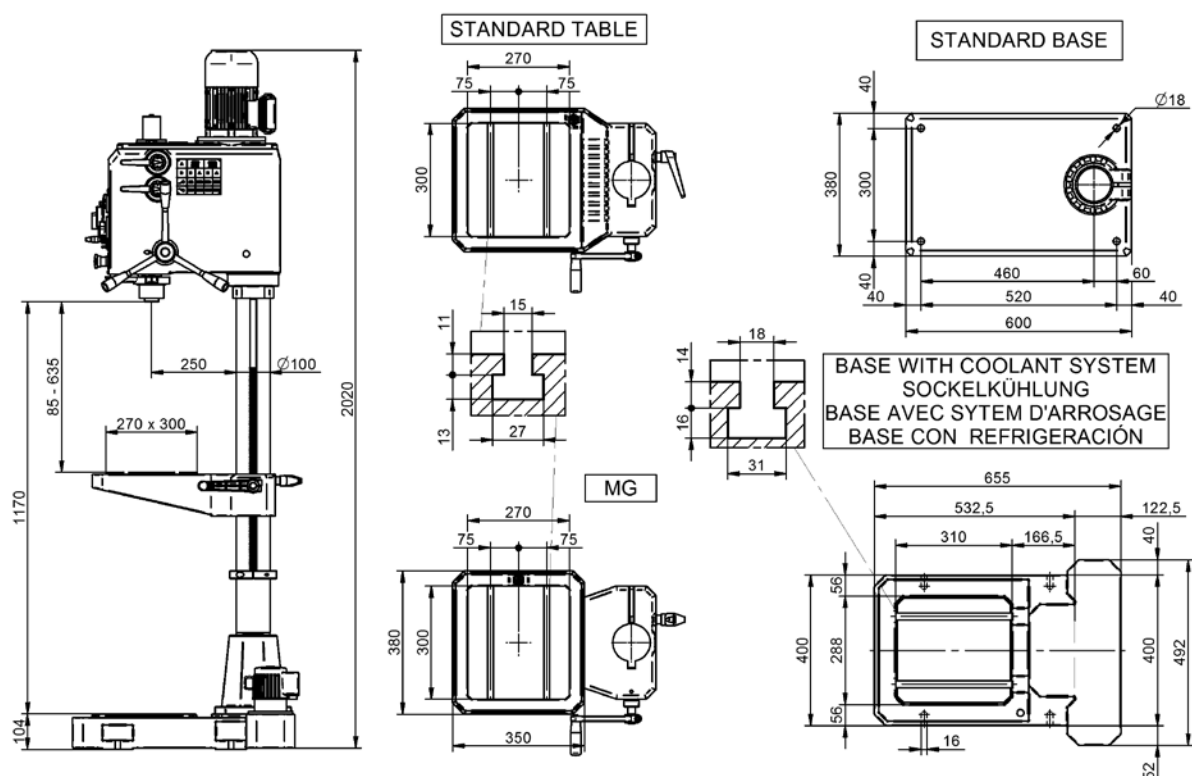

# SERIE GP.40-50

## PROFESSIONAL

- Automatic feed - mechanical clutch
- Geared drive
- Displaceable table and fixed headstock



## Standard equipment

- Adjustable depth end
- Tool ejector
- Motor guard and emergency push button
- Turning sense selector
- Electrical equipment at low voltage
- Drill guard with stop micro
- Fixed table (in models GP.40)
- Rotating and tilting table (in models GP.50)
- Frontal wheel for fine sensitive feed (in models GP.50)
- CE norms



**GP.40**

## Extra Equipment

	CODE
L - LIGHTING EQUIPMENT	20010
IR/RS - MANUAL TAPPING SYSTEM IR/RS	10042
MGI - ROTATING AND TILTING TABLE (STANDARD FOR GP.50)	30084
MGM - REVERSIBLE ROTATING TABLE WITH VICE (ONLY FOR GP.40)	20087
ERB - COOLANT EQUIPMENT IN THE BASE	91118

# Characteristics

	GP.40	GP.50
DRILLING CAPACITY IN STEEL OF 70 KG. (mm)	40	50
TAPPING CAPACITY IN STEEL OF 70 KG.	M30	M35
TRANSMISSION	GEARS (Hardened and grounded)	
SPEED NUMBER AND RANGE 50Hz.	75-150-235-325-470-650 1050-2100 rpm.	93-152-204-298-443 695-970-1420 rpm.
MAIN MOTOR POWER (rpm)	1,8/3,2 HP - 750/1500 rpm.	4 HP - 1500 rpm.
FEED	AUTOMATIC	
NUMBER AND RANGE OF FEEDS	(3) 0,10-0,20-0,30	(3) 0,10-0,18-0,24
CLUTCH	MECHANIC	
SPINDLE CONE	MT4	
SPINDLE STROKE	160 mm	180 mm
DISTANCE SPINDLE-COLUMN	300 mm	350 mm
DISTANCE SPINDLE-TABLE	Min. 70 mm/ Max. 885 mm	Min. 95 mm/ Max. 865 mm
DISTANCE SPINDLE-BASE	1230 mm	1220 mm
COLUMN DIAMETER	Ø125 mm	Ø150 mm
DIMENSIONS OF THE TABLE WITH T SLOTS	400x420 mm	480x480 mm
DIMENSIONES OF THE BASE	400x655 mm	
COOLANT EQUIPMENT	NO	
LIGHTING EQUIPMENT	NO	
WEIGHT: NET / GROSS KG.	300/400 Kg.	435/565 Kg.
PACKAGING DIMENSIONS AND VOLUME	2,37x0,6x0,96 / 1,37 m <sup>3</sup>	2,38x0,62x1,05 / 1,55 m <sup>3</sup>

# Dimensions

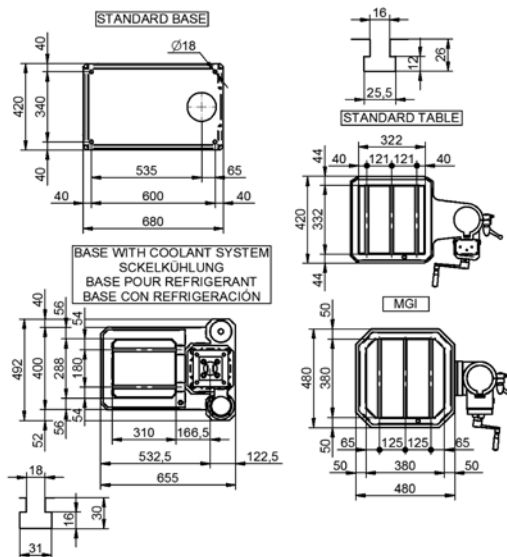
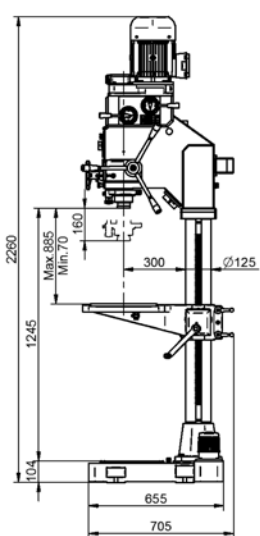

**GP.40**

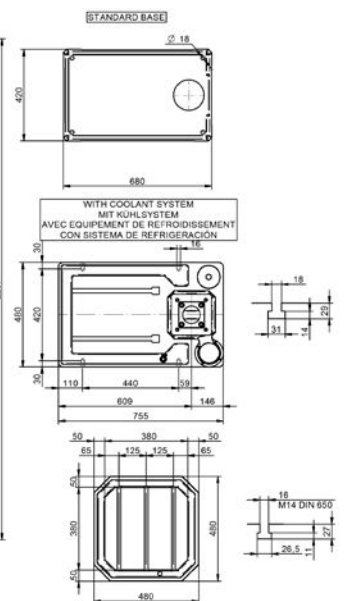
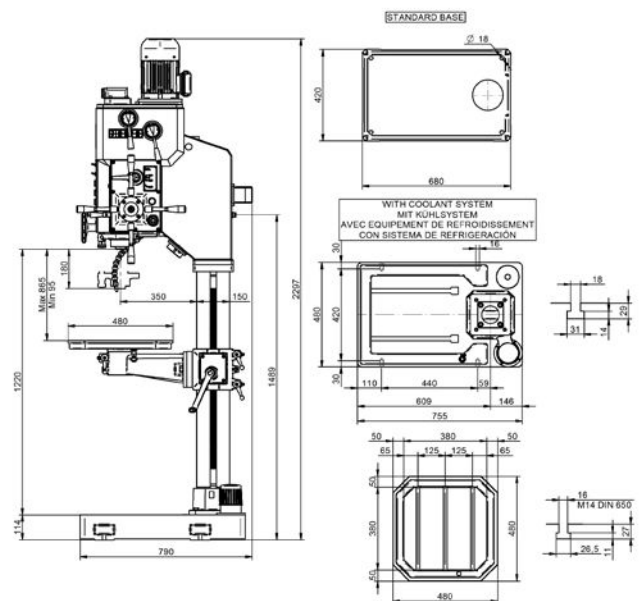

**GP.50**

# SERIE TF

## PRISMATIC COLUMN DRILLING MILLING MACHINE

- Automatic feed - Electromagnetic clutch
- Geared drive
- Cross table
- Fixed base and displaceable headstock



### Standard equipment

- Motorized headstock displacement
- Prismatic column
- Guides, Column and table manual greasing pump
- Depth adjustable end
- Frontal wheel for fine sensitive feed
- Coolant equipment
- Tool spanning system
- Lighting equipment
- Main switch
- Emergency push button
- Turning sense selector
- Electrical equipment at low voltage
- Command plate installed in articulated arm
- Drill guard with stop micro
- CE norms



TF.35

### Extra Equipment

	CODE
LBC - DEPTH DIGITAL READER	50012
IR/RS - TAPPING SYSTEM IR/RS	50020
RPF - AUTOMATIC TAPPING SYSTEM BY LEAD SCREW WITH BRACKING DEVICE (INCLUDES ONE LEAD SCREW)	50035
HGP-S - ADDITIONAL LEAD SCREW, SPECIAL PITCH	50038
HGP - ADDITIONAL LEAD SCREW, STANDARD PITCH	50040
ENG X - AUTOMATIC LONGITUDINAL DISPLACEMENT BY MOTORIZED FEED BOX	50070
ENG Y - AUTOMATIC TRANSVERSAL DISPLACEMENT BY MOTORIZED FEED BOX	50080
LDG-1 - 1 AXIS DIGITAL VIEWER (IN COMMAND PLATE OVER AN ARTICULATED ARM)	50089
LDG-2 - 2 AXIS DIGITAL VIEWER (IN COMMAND PLATE OVER AN ARTICULATED ARM)	50090
LDG-3 - 3 AXIS DIGITAL VIEWER (IN COMMAND PLATE OVER AN ARTICULATED ARM)	50100
PPZ - COLLET HOLDER, SET OF COLLETS, KEY, BOX AND LOCKING NUT	50120
SC - COLUMN SUPPLEMENT 250 MM.	50130
ISO-30 - EXTRA PRICE FOR SPINDLE ISO.30	50140
ISO-40 - EXTRA PRICE FOR SPINDLE ISO.40	50141
SAH - AUTOMATIC TOOL ADJUSTING FOR CONE ISO	50170
PRO - COLUMN PROLONGATION	50220
ACNL -RAPID APPROACH AND RETURN WITH PNEUMATIC COUNTERWEIGHT	50250
CI - INTEGRAL DRILLING CYCLE FOR TUBES/PROFILES AND INTERMITTANCES	50255

# Characteristics

## TF.35

DRILLING CAPACITY IN STEEL OF 70 Kg. (mm)	35
TAPPING CAPACITY IN STEEL OF 70 Kg. (mm)	M35
MILLING CAPACITY (mm)	55
TRANSMISSION	GEARS (Hardened and grounded)
NUMBER AND RANGE OF SPEEDS (RPM.) 50 Hz.	(16) 94 - 2225 rpm.
FEED	AUTOMÁTICO
NUMBER AND RANGE OF FEEDS	(3) 0,10-0,18-0,24
CLUTCH	ELECTROMAGNETIC
MAIN MOTOR POWER	1,2/2 HP
MAIN MOTOR SPEED (rpm.)	750/1500 rpm.
SPINDLE CONE	MT4
SPINDLE STROKE	180
DISTANCE SPINDLE-COLUMN	390
DISTANCE SPINDLE-TABLE	Min. 190 / Max. 650
DIMENSIONS OF THE CROSS TABLE	360x1220 mm
MANUAL CROSS TABLE STROKE (STANDARD)	X=700 / Y=360
MOTORIZED CROSS TABLE STROKE (EXTRA OPTIONAL EQUIPMENT)	X=650 / Y=350
TABLE WITH "T" SLOTS	SI
TILTING TABLE	45° A CADA LADO
WEIGHT: NET/GROSS Kg.	910 / 1400 KG.
PACKAGING DIMENSIONS AND VOLUME	2,52x1,68x1,68 / 7,11 m <sup>3</sup>

# Dimensions

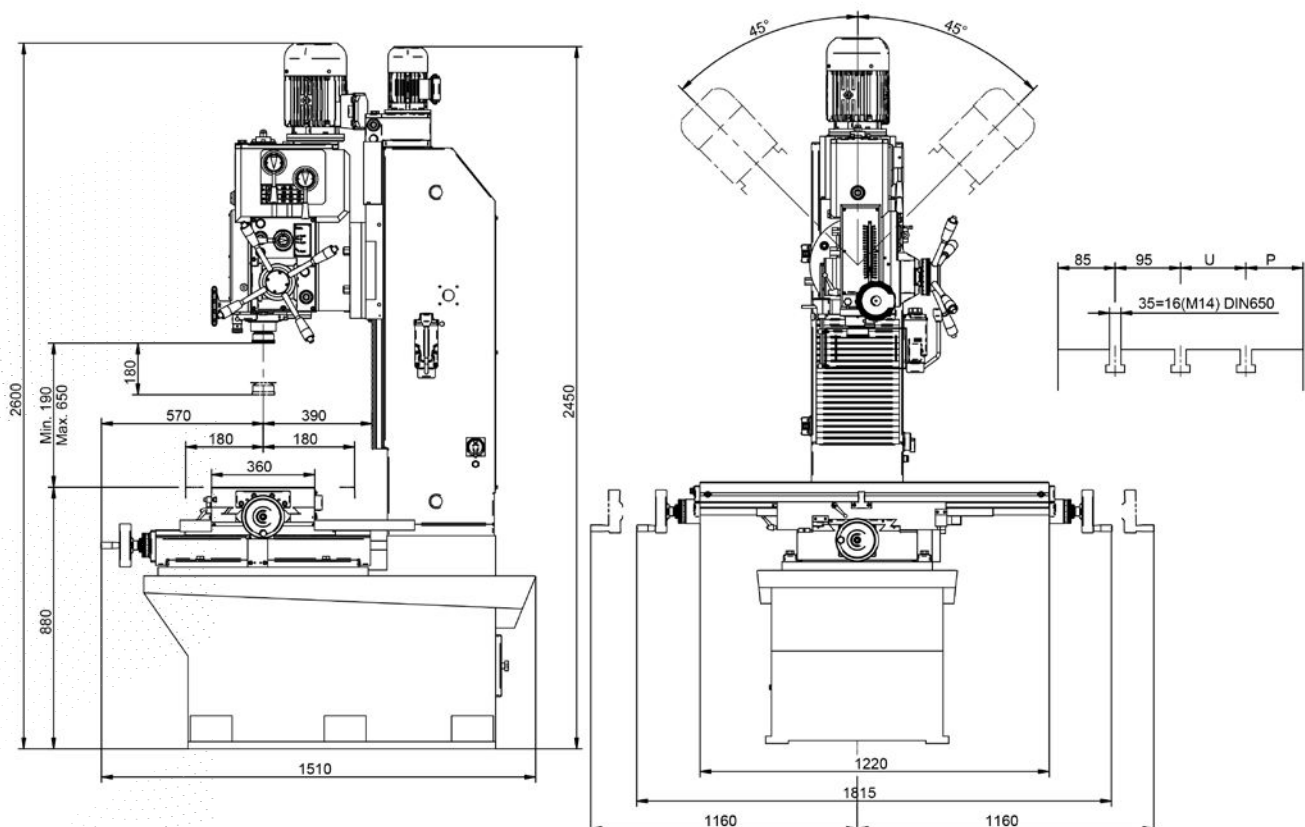

# GANG DRILLING MACHINES

...



MS.30



BSR/4L

[www.erlogroup.es](http://www.erlogroup.es)

If you need further information or a quotation for any of this type of machines, please contact to:

**[erlogroup@erlogroup.es](mailto:erlogroup@erlogroup.es)**  
**Tel. +34 943 851 858**



**BTSAR.35**



**BSHR**

# SELECTION AND FEATURES OF A DRILLING/TAPPING MACHINE

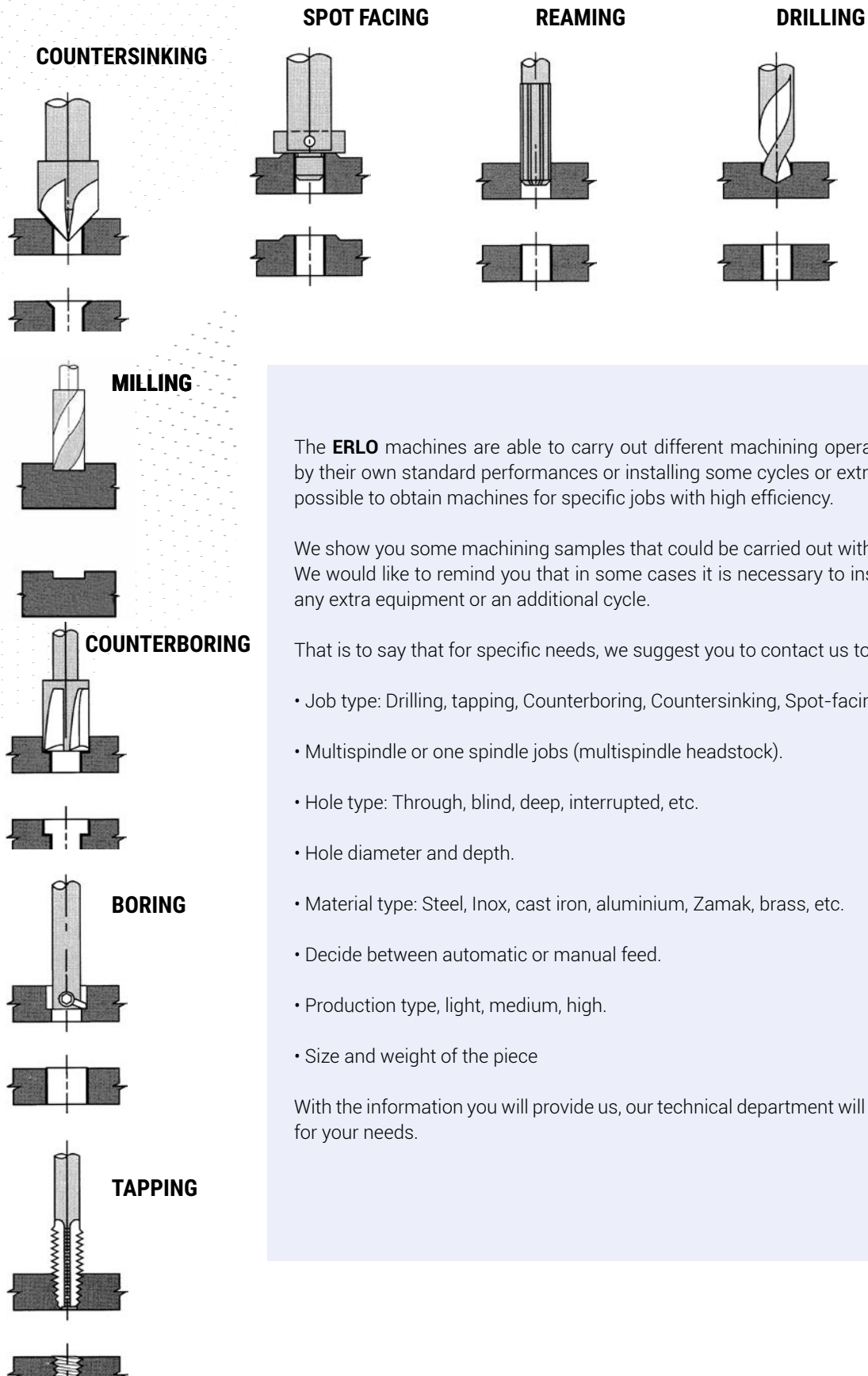

The **ERLO** machines are able to carry out different machining operations. It is obtained by their own standard performances or installing some cycles or extra equipment, so it is possible to obtain machines for specific jobs with high efficiency.

We show you some machining samples that could be carried out with our machines. We would like to remind you that in some cases it is necessary to install on the machine any extra equipment or an additional cycle.

That is to say that for specific needs, we suggest you to contact us to show your needs:

- Job type: Drilling, tapping, Counterboring, Countersinking, Spot-facing, reaming, etc.
- Multispindle or one spindle jobs (multispindle headstock).
- Hole type: Through, blind, deep, interrupted, etc.
- Hole diameter and depth.
- Material type: Steel, Inox, cast iron, aluminium, Zamak, brass, etc.
- Decide between automatic or manual feed.
- Production type, light, medium, high.
- Size and weight of the piece

With the information you will provide us, our technical department will quote you a solution for your needs.



## TOOL FASTENING

### DRILL CHUCKS

Quick lock or by key, to adapt cylindrical sleeve drills. Different sizes and measures.

These are supplied with shank adaptor for their adjustment on the machine cone.



### REDUCTION SLEEVES

To adjust the cone tools with inferior size than the morse taper of the machine.



### RAPID CHANGE DEVICES

Tool holders and adapters for rapid change of different tools. There is no need to stop the machine spindle turning.

There are adapters for drills with sleeve Morse Taper 1, 2, 3, 4 and 5, drill chucks, tap holders, etc.



### CONICAL BUSHING

To adjust the drills with parallel shank or taps to the machine or multispindle headstock cones.

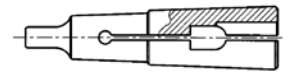

### TAP HOLDERS

PNR, Without turning inversion, to fit on machines with automatic inversion of the turning sense.

PR, With automatic inversion of the turning sense. To fit on machines which are not provided with automatic inversion turning. Different models and capacities.



### COLLET CHUCKS

Collet chucks and set of collets to install different tools.

It is supplied complete with a collet chuck, set of collets, box, key and adaptation nut.



## PIECE ADJUSTING

### VICES

L-100 - FIXED BASE. OPENING 116 mm - JAWS WIDTH 105 mm

L-125 - FIXED BASE. OPENING 160 mm - JAWS WIDTH 125 mm

M116 - FIXED BASE. OPENING 116 mm - JAWS WIDTH 105 mm

M157 - FIXED BASE. OPENING 157 mm - JAWS WIDTH 125 mm

M190 - FIXED BASE. OPENING 190 mm - JAWS WIDTH 150 mm

MG116 - ROTATING BASE. OPENING 116 mm - JAWS WIDTH 105 mm

MG157 - ROTATING BASE. OPENING 157 mm - JAWS WIDTH 125 mm

MG190 - ROTATING BASE. OPENING 190 mm - JAWS WIDTH 150 mm

PF150 - FIXED BASE. OPENING 150 mm. - JAWS WIDTH 160 mm.

PG150 - ROTATING BASE. OPENING 150 mm. - JAWS WIDTH 160 mm.

FR-80 - FIXED BASE. OPENING 80 mm. - JAWS WIDTH 80 mm.

FR-125 - FIXED BASE. OPENING 125 mm. - JAWS WIDTH 125 mm.

FK-103 - FIXED BASE. OPENING 110 mm. - JAWS WIDTH 128 mm.



SERIE L



SERIE M



SERIE MG



FR-125

### Pneumatic chucks

- Mechanical, pneumatic, hydraulic.
- Measures from 160 up to 400.

Automatic or manual operating. Possibility of synchronised functioning with the machine cycle.

Provided with 2, 3 or 4 jaws and also in special execution for specific jobs and parts.



### TOOL SET UP

Designed by our technical department, they are adjusted to the specific needs of each customer.

# EXTRA ACCESSORIES

## PARTS DISPLACEMENT

### CROSS TABLES

MH.360X1220 - DISPLACEMENT BY SPINDLES X=700 / Y=360 mm

340 XY - SURFACE 340X190. STROKES X=220 / Y=140 mm

430 XY - SURFACE 430X240. STROKES X=280 / Y=180 mm

600 XY - SURFACE 600X240. STROKES X=400 / Y=180 mm

800 XY - SURFACE 800X280. STROKES X=500 / Y=250 mm

1000 XY - SURFACE 1000X280. STROKES X=700 / Y=250 mm

DLC - AUTOMATIC LONGITUDINAL DISPLACEMENT OF THE TABLE, WITH MOTORIZED FEED BOX

DTC - AUTOMATIC TRANSVERSAL DISPLACEMENT OF THE TABLE, WITH MOTORIZED FEED BOX

VD-2 - 2 AXIS DIGITAL VIEWER, X-Y CENTESIMAL READING



430 XY (MS.204)

### INDEXING TABLES

- Electronic
- Hydraulic

Different sizes and indexes to adapt us to your needs. Simple fitting on the machine. Manual, automatic or synchronised movements with the machine cycle.



## CONTROL AND READING

### EQUIPMENT AND DIGITAL READING

1, 2 or 3 axis viewer, to read out the strokes of the cross tables and the main spindle. Centesimal reading out.

It is supplied integrated in a command plate over an articulated arm.



### DIGITAL RULERS

Digital ruler to read the strokes of the main spindle. It is installed directly over the headstock.



## MULTISPINDLE HEADSTOCKS



### MULTISPINDLE HEADSTOCKS

TYPE	N° OF SPINDLES		Ø DRILLING	AREA	SHAPE	
EXCENTRIC	2 A 4		2 A 25		A,B,C	
UNIVERSAL JOINT	2 A 18		2 A 25		A,B,C,D,E,F	
SPECIAL FIXED SPINDLES	2 A 20		2 A 25		A,B,C,D,E,F	
SHAPE	A	B	C	D	E	F
	• •	• • •	• • • •	• • • •	• • • •	• • • • • • • •

## TAPPING SYSTEMS

### TAPPING SYSTEM IR/RS

Semi-automatic tapping system for auxiliary operations and small tapping productions.



### TAPPING SYSTEM BY LEAD SCREW

Automatic tapping system for big production operations.  
Tapping system by lead screw (one lead screw included).  
Tapping system by lead screw with bracking by variator (one lead screw included).



## HIDROBLOCK

STANDARD CYCLE



CYCLE UPON REQUEST

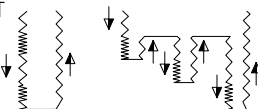

# EXTRA ACCESSORIES

## NEUMATIC CYCLES

### SYNCHRONISED PNEUMATIC CYCLE

Spindle cycle automation synchronising the rapid approach and return movements with the drilling feed.

SYNCHRONISED PNEUMATIC CYCLE

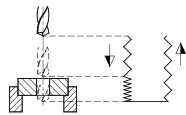

PIPE AND PROFILES CYCLE

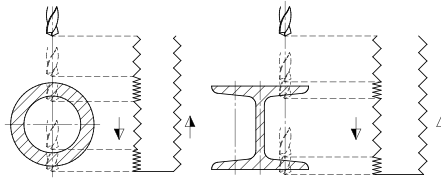

PECK DRILLING CYCLE

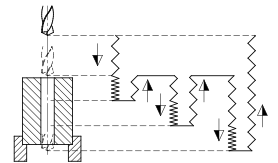

## FLOW DRILLING + TAPPING

### FLOW DRILLING

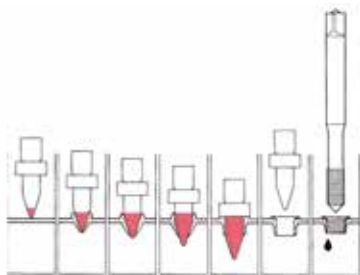

### STARTING KIT



### SAMPLES



## INTERMEDIATE TABLES FOR BENCH TYPE DRILLING MACHINES



MIF - FIXED INTERMEDIATE TABLE



MIG - ROTATING INTERMEDIATE TABLE

## REVERSIBLE TABLES WITH VICE FOR COLUMN DRILLING MACHINES



125 Reversible rotating table with vice for models serie TSA-TSE.32, V-VP.35-40 and GP.40

## COMMAND OPTIONS



Bi manual command



Cycle start foot switch

For more information...

**[www.erlogroup.es](http://www.erlogroup.es)**





**ERLO**  
Drills / Units / CNC

**ERLO**  
Group

Erlo  
Iberdrill  
Ibermach  
Erlo Service

[www.erlogroup.es](http://www.erlogroup.es)

Txerloie auzoa n°3  
20720 AZKOITIA (SPAIN)

T: +34 943 851 858

Email : [erlogroup@erlogroup.es](mailto:erlogroup@erlogroup.es)